

ADDENDUM #2

DATE: **January 4, 2017**

TO BIDDING DOCUMENTS ENTITLED:

**Boone County Backup 911
609 East Walnut Street
Bid Number: 54-29DEC-16**

PROJECT NUMBER: PWA 201617

BID DATE: ~~1:00 PM, Thursday, December 29, 2016~~
~~Bids Due: 1:00 PM, Thursday, January 5, 2017~~
Bids Due: 9:00 AM, Tuesday, January 10, 2017
Bid Opening: 9:30 AM, Tuesday, January 10, 2017

PREPARED FOR: **Boone County, Missouri
Jacob M. Garrett, Buyer
613 East Ash Street, Room 109
Columbia, MO 65201
Phone: (573) 886-4393
Fax: (573) 886-4390
E-mail: JGarrett@boonecountymo.org**

CONSULTANT: **Peckham & Wright Architects
Attn: Erik Miller
2120 Forum Blvd., Ste. 101
Columbia MO 65203
Telephone: (573) 449-2683
Fax: (573) 442-6123
Email: emiller@PWArchitects.com**

Drawings and Specifications for the above noted project and the work covered thereby are herein modified as follows, and except as set forth herein, otherwise remain unchanged and in full force and effect:

General:

- 1. The Bid date has been changed to Tuesday January 10, 2017 at 9:00AM. All bids must be received at County Purchasing prior to that time.**
- 2. Pre-bid Meeting:** The list of attendees and the outline for the pre-bid meeting are attached.
- 3. Notice to Bidders:** Contract Time: The current listing indicates Calendar Days listed on the bid form of the selected bidder. **Calendar days should read Working days as indicated on the bid form.**
- 4. Bid Form: Clarification:** Time of Completion: The current bid form requires the Contractor to list Working days to establish the project schedule. The pre-bid agenda and meeting indicated consecutive calendar days. **The bidder should list Working days as indicated on the bid form.**
- 5. Bid Form Clarification:** Time of Completion and Liquidated Damages: The Owner will be supplying the generator and transfer switch for installation by Contractor. The work for the installation of the generator and transfer switch will not be counted against the work days listed in the bid form as the delivery date for the generator has yet to be determined. All other work indicated for setup and utilities to the generator should be completed within the established period based on the working days listed. The Contractor is responsible for installation of the generator immediately when delivered and will not delay other work as a result.

6. **Substitutions:** Contractors may choose to substitute products specified provided that the substitution procedures indicated in Specification Section 01 6000 Product Requirements are followed unless specifically indicated in a specification section. The bid documents contain a Request for Substitution (RFS) form that should be filled out and submitted by the bidder.
7. **Clarification:** All computer network cabling will be supplied and installed by the Owner under a separate contract. The Contractor will need to cooperate and coordinate with that network contractor. All current low voltage wiring for fire alarm and other systems indicated in the documents is the responsibility of the Contractor.
8. **Clarification:** Work phasing: Due to the nature of the systems integration for the Owner the work for completing the Server Room construction will take precedence in scheduling. The Contractor should assume a schedule to complete the work for the Server Room as quickly as possible through the course of work on the entire project. This would include complete finishing of the room with dust protection over the installed door to protect installed equipment.
9. **Clarification:** Painting scope of work: All doors and frames indicated on the floor plan with the exception of the door into the Server Room are to remain and will not be painted. The door and frame into the Server Room is indicated on the floor plan to be a relocated door. The frame for that door should be re-painted after installation.
10. **Clarification:** Existing Carpet Tile: The existing carpet tile for removal and reinstallation is Lees Photofinish, 118, Silverstone with Eco-Flex Backing. This product has been discontinued by the manufacturer however the installer should verify removal and reinstallation requirements with the manufacturer.

Drawings:

1. **Sheet A101:** A1/A101 Floor Plan: Scope of Work Note 11 indicates the concrete slab for the generator in the parking lot to the West of the building. The dimensions of the slab are to be 9'-0" long x 4'-0" wide.
2. **Sheet A102:** Details E1 and E4/A102: All gypsum board should be corrected to read 5/8" thickness.
3. **Sheet M1.1:** The new gas meter which will replace the existing shall be sized for 1260 MBH.
4. **Sheet M1.1:** The gas piping to the generator shall be revised to 2-1/2" diameter pipe size.
5. **Sheet M1.1:** The piping indicated on drawing M2.1 between the humidifier steam generator and the humidifier dispersion unit shall be labeled as steam piping.
6. **Sheet M1.1:** Add a 1/2" Watts model LF-009QT reduced pressure zone backflow preventer to the domestic cold water line feeding the humidifier.
7. **Sheet M1.1:** Add 1/2" ball valves and unions at the connections of the domestic cold water piping to the humidifier and humidifier Drane Kooler.
8. **Sheet M1.1:** Add a gas cock and union to the gas piping at the generator connection.
9. **Sheet M1.1:** Route the 3/4" condensate drain from FC-7 above the ceiling back to the mop sink in the Janitor's closet.
10. **Sheet M2.1:** Add the roof piping mounting detail for the gas piping per the attached drawing M2.1-1.
11. **Sheet E2.1:** Install three 8' x 3/4" diameter ground rods spaced 8' apart in the exterior space to the East of the building. Bond #2 THHN, CU GRD wire to ground rods and route into the new server room through one of the 4" diameter communications conduits leaving a 20' coil of ground wire in the server room for the owner to terminate the ground wire.
12. **Sheet E3.1:** Electrical panels P2 and P3 shall be 225 A, MLO panels.
13. **Sheet E3.1:** Add the panel schedule for panel P3 per the attached drawing E3.1-1.

END OF ADDENDUM



Peckham & Wright Architects, Inc.

2120 Forum Blvd., Ste. 101
Columbia, Missouri 65203
(573) 449-2683
Fax: (573) 442-6213

Boone County Backup 911

609 East Walnut Street
Columbia, Missouri
PWA 201617

Pre-Bid Meeting Agenda

Thursday, December 22, 2016 – 3:00 pm CDT

1) Introductions

2) Attendance Record- Attendance is Mandatory to submit a bid.

3) Questions During Bidding

- a) All questions must be submitted in writing to be binding (e-mail is ok). Addenda will be issued to respond to questions. Forms are included in the project Manual for Request for Clarification and for Product Substitution.
- b) Contact for questions

Jacob M. Garrett, Buyer
613 East Ash Street, Room 109
Columbia, MO 65201
Phone: (573) 886-4393
Fax: (573) 886-4390
E-mail: JGarrett@boonecountymmo.org

4) Review of Notice to Bidders

- a) Sealed Bids for a Stipulated Sum Contract
- b) Bids are Due – Thursday, January 5, 2017 at 1:00 pm.
- c) Bonds
 - 1) Bidder's check/draft or Approved Surety in the amount of five percent (5%)
 - 2) Performance and Bonds 100% of base bid
- d) Bidding Documents Availability-ADS in Columbia
- e) State of Missouri Prevailing Wage Law

5) Bid Form Submit all forms required for attachment to bid form

- 1) One Alternate (Clean Agent Fire Extinguishing System)
- 2) Form must be completely filled out
- 3) Construction time established by accepted bid listed on the form
- 4) Consecutive Calendar Day contract with \$500.00 per day Liquidated Damages.

6) Instructions to Bidders

7) Bid Response

8) Bid Bond

PRE-BID MEETING
RFB – 54-29DEC16 – BOONE COUNTY BACKUP 911
12-22-16 – 3:00 P.M.

	Representative Name	Business Name	Telephone Number
1.	Jacob M. Garrett	Boone County Purchasing	573-886-4393
2.	<i>Jared M. ...</i>	Boone Co. Commission	573-886-4307
3.	<i>Charles Nichols</i>	" " "	573-999-2020
4.	LARRY BAKER	Summit Mech.	573-808-1630
5.	Mike Bungart	G.P.W Builders	573-893-3633
6.	Walt Inhoff	Inhoff Construction	573-619-2050
7.	Jason Russell	Kaiser Electric	573-462-0206
8.	TROY PINKERTON	G+T Construction	573-694-9990
9.	DAVE RIDGE	CARPET MART	874-7900
10.	Craig Linhardt	Meyer Electric	573-893-2335
11.	GRAIG SIMON	FCE	573-442-1113 x222
12.	Phad Baker	Phad Baker Const	573-489-6470
13.	Gary Wegers	Loftis Co. LLC	573-881-0196
14.	Chris Costner	Tech Electronics	573-239-4362
15.	Scott Wallace	Mid Missouri Electric	573-875-1545

PRE-BID MEETING
RFB – 54-29DEC16 – BOONE COUNTY BACKUP 911
12-22-16 – 3:00 P.M.

	Representative Name	Business Name	Telephone Number
1.	Jacob M. Garrett	Boone County Purchasing	573-886-4393
2.	Beth Boos	Boone County IT	573-289-3080
3.	ERIC MEUER	FW Architects, Inc	573-449-2683
4.	Clay Mitchev	Grave Construction LLC	573-777-9599
5.	Drew Harris	Carroll Construction, LLC	573-239-7575
6.	Chris Hunt	Koch Air	618-444-6899
7.	Chad Martin	BCJC	
8.	Wayne A. Stegner	CM ENGINEERING	573-874-9455
9.	David D. Dunford	BCX	913-209-9561
10.	Mate Mornhoff	Little Dixie Const.	(573) 449-7200
11.	Brice Moewer	Brooke Drywall	573 474-7676
12.	Kurt Klebbq	Clearview Enterprises	573-635-6560
13.			
14.			
15.			

PANEL DESIGNATION

P8

PANEL DESCRIPTION

208 VOLTS, 3Ø, 4W, 5W, 225A MLO, 42 CIRCUIT, INVRD, BAR KIT, SQ D NGOD

CIRC #	CIRCUIT DESCRIPTION	BRKR AMPS	BRKR POLES	WATTS PER PHASE			BRKR POLES	BRKR AMPS	CIRCUIT DESCRIPTION	CIRC #
				A	B	C				
1	411 WORKSTATION	20	1	500						
				500			1	20	TV OUTLET	2
3	411 WORKSTATION	20	1		500					
					1000		1	20	TV OUTLET	4
5	411 WORKSTATION	20	1							
						582	2	15	DAIKIN FC'S	6
7	MICROWAVE	20	1	500						
				582			-	-		8
9	DATA ROOM LIGHT	20	1		200					
					500		1	20	411 WORKSTATION	10
11	DATA ROOM OUTLET	20	1							
						1000				
						500	1	20	FACP	12
13	411 WORKSTATION	20	1	500						
				500			1	20	HVAC CONTROLS	14
15	SPARE	20	1							
						500	1	20	FIRE SUPPRESSION CONTROLS	16
17	SPARE	20	1							
										18
19	SPARE	20	1							
										20
21	SPARE	20	1							
										22
23										
										24
25										
										26
27										
										28
29										
										30
31										
										32
33										
										34
35										
										36
37										
										38
39										
										40
41										
										42
TOTAL VOLT-AMPS (VA) PER PHASE:				4082	2700	2082				
TOTAL CONNECTED LOAD (VA):				8864						
DIVERSITY (VA)										
SIMULTANEOUS LOAD (VA):				8864						
TOTAL AMPS				25						



CM ENGINEERING
 2801 Woodard Drive
 Suite 105
 Columbia, Missouri
 65202
 PH - 573/874-9455
 Fax - 573/874-9474

REV NO. DATE/REASON:
 12-29-16
 ADDENDUM 1

BOONE COUNTY
BACK UP 911
 609 EAST WALNUT ST
 COLUMBIA, MO 65201

DATE ISSUED:
 12-29-16
E3.1-1
 PROJECT NO.
 16024

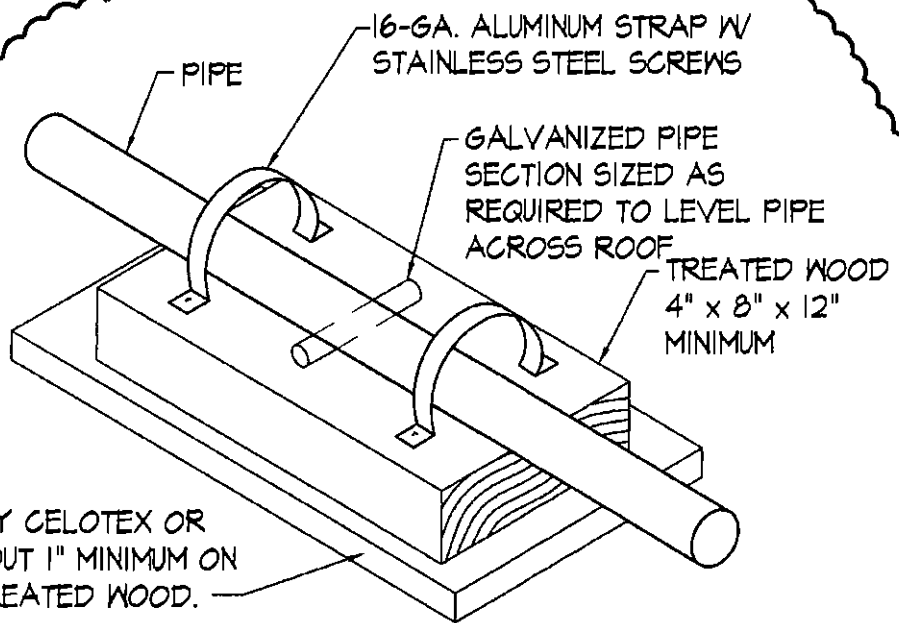

01 PIPE SUPPORT ON ROOF

NO SCALE



CM
ENGINEERING
2801 Woodard Drive
Suite 105
Columbia, Missouri
65202
Ph. - 573/874-9455
Fax - 573/874-9474

REV NO. DATE/REASON:
 12-29-16
 ADDENDUM I

**BOONE COUNTY
BACK UP 911**
 609 EAST WALNUT ST
 COLUMBIA, MO 65201

DATE ISSUED:
12-29-16
 **M2.1-1**
 PROJECT NO.
16024