



Boone County Purchasing
601 E. Walnut, Room 208
Columbia, MO 65201

Request for Bid (RFB)

Heather Turner, CPPB, Buyer
(573) 886-4392 – Fax: (573) 886-4390
Email: hturner@boonecountymo.org

Bid Data

Bid Number: **22-28MAR06**
Commodity Title: **Street Name Signs Term & Supply**

DIRECT BID FORMAT OR SUBMISSION QUESTIONS TO THE PURCHASING DEPARTMENT

Bid Submission Address and Deadline

Day / Date: **TUESDAY – March 28, 2006**
Time: **1:30 P.M. (Bids received after this time will be returned unopened)**
Location / Mail Address: **Boone County Purchasing Department
Boone County Johnson Building
601 E. Walnut, Room 208
Columbia, MO 65201**
Directions: The Johnson Building is located on the Northeast corner at 6th Street and Walnut Street. Enter the building from the East Side. Wheel chair accessible entrance is available on the West side of the building.

Bid Opening

Day / Date: **TUESDAY – March 28, 2006**
Time: **1:30 P.M. C.S.T.**
Location / Address: **Boone County Johnson Building Conference Room
601 E. Walnut, Room 213
Columbia, MO 65201**

Bid Contents

- 1.0: **Introduction and General Conditions of Bidding**
- 2.0: **Primary Specifications**
- 3.0: **Response Presentation and Review**
- 4.0: **Response Form
Standard Terms and Conditions**

1. Introduction and General Conditions of Bidding

- 1.1. **INVITATION** - The County of Boone, through its Purchasing Department, invites responses, which offer to provide the goods and/or services identified on the title page, and described in greater detail in Section 2.
- 1.2. **DEFINITIONS**
- 1.2.1. **County** - This term refers to the County of Boone, a duly organized public entity. It may also be used as a pronoun for various subsets of the County organization, including, as the context will indicate:
Purchasing - The Purchasing Department, including its Purchasing Director and staff.
Department(s) or Office(s) - The County Department(s) or Office(s) for which this Bid is prepared, and which will be the end user(s) of the goods and/or services sought.
Designee - The County employee(s) assigned as your primary contact(s) for interaction regarding Contract performance.
- 1.2.2. **Bidder / Contractor / Supplier** - These terms refer generally to businesses having some sort of relationship to or with us. The term may apply differently to different classes of entities, as the context will indicate.
Bidder - Any business entity submitting a response to this Bid. Suppliers, which may be invited to respond, or which express interest in this bid, but which do not submit a response, have no obligations with respect to the bid requirements.
Contractor - The Bidder whose response to this bid is found by Purchasing to meet the best interests of the County. The Contractor will be selected for award, and will enter into a Contract for provision of the goods and/or services described in the Bid.
Supplier - All business(s) entities which may provide the subject goods and/or services.
- 1.2.3. **Bid** - This entire document, including attachments. A Bid may be used to solicit various kinds of information. The kind of information this Bid seeks is indicated by the title appearing at the top of the first page. A "Request for Bid" is used when the need is well defined. A "Request for Proposal" is used when the County will consider solutions, which may vary significantly from each other or from the County's initial expectations.
- 1.2.4. **Response** - The written, sealed document submitted according to the Bid instructions.
- 1.3. **BID CLARIFICATION** - Questions regarding this Bid should be directed in writing, by e-mail or fax, to the Purchasing Department. Answers, citing the question asked but not identifying the questioner, will be distributed simultaneously to all known prospective Bidders in the form of an addendum. We strongly suggest that you check for any addenda a minimum of [forty eight] hours in advance of the bid deadline. Bids, addendums, bid tabulations and bid awards are posted on our web site at: www.showmeboone.com
 Note: written requirements in the Bid or its Amendments are binding, but any oral communications between County and Bidder are not.
- 1.3.1. **Bidder Responsibility** - The Bidder is expected to be thoroughly familiar with all specifications and requirements of this Bid. Bidder's failure or omission to examine any relevant form, article, site or document will not relieve them from any obligation regarding this Bid. By submitting a Response, Bidder is presumed to concur with all terms, conditions and specifications of this Bid.
- 1.3.2. **Bid Amendment** - If it becomes evident that this Bid must be amended, the Purchasing Department will issue a formal written Amendment to all known prospective Bidders. If necessary, a new due date will be established.
- 1.4. **AWARD** - Award will be made to the Bidder(s) whose offer(s) provide the greatest value to the County from the standpoint of suitability to purpose, quality, service, previous experience, price, lifecycle cost, ability to deliver, or for any other reason deemed by Purchasing to be in the best interest of the County. Thus, the result will not be determined by price alone. The County will be seeking the least costly outcome that meets the County needs as interpreted by the County. The County reserves the right to award this bid on an item by item basis, or an "all or none" basis, whichever is in the best interest of the County. The County also reserves the right to not award any item or group of items if the services can be obtained from cooperative MMPPC or other government contracts under more favorable terms.
- 1.5. **CONTRACT EXECUTION** - This Bid and the Contractor's Response will be made part of any resultant Contract and will be incorporated in the Contract as set forth, verbatim.
- 1.5.1. **Precedence** - In the event of contradictions or conflicts between the provisions of the documents comprising this Contract, they will be resolved by giving precedence in the following order:
 1) the provisions of the Contract (as it may be amended);
 2) the provisions of the Bid;
 3) the provisions of the Bidder's Response.
- 1.6. **CONTRACT PERIOD** - The Term and Supply Contract period shall be from April 1, 2006 through March 31, 2007 and may be automatically renewed for up to an additional two (2) one-year periods unless canceled by the Purchasing Director in writing prior to a renewal term.
- 1.7. **COMPLIANCE WITH STANDARD TERMS AND CONDITIONS** - Bidder agrees to be bound by the County's standard "boilerplate" terms and conditions for Contracts, a sample of which is attached to this Bid.

2. Primary Specifications

- 2.1. **ITEMS TO BE PROVIDED** - Boone County, hereafter referred to as "County", proposes to contract with an individual(s) or organization(s), hereinafter referred to as "Contractor" for a Term and Supply contract for the Furnishing and Delivery of **Street Name Signs** as needed for the Boone County Public Work's Department.
- 2.1.1. **Quantity** - All sign orders shall be placed on a weekly and/or as needed basis. The County **does not** guarantee a minimum quantity per order. Boone County reserves the right to adjust or delete any and all ordered quantities and may at times request to make a change to the original description of the street name sign. The estimated quantities provided should not be construed as exact quantities to be ordered. The quantities specified herein are estimates only based on past usage and anticipated future requirements, and as such, do not constitute a guarantee on the part of the County.
- 2.2. **CONTRACT DURATION** - The contract shall be effective from April 1, 2006 through March 31, 2007. This contract is subject to renew annually for two (2) additional one (1) year periods following expiration of the first contract period. Prices are subject to adjustment thereafter, effective on the renewal date, and must remain firm through the end of the renewal period.
- 2.2.1. **Contract Extension** - The County Purchasing Director may exercise the option to extend the contract on a month to month basis for a maximum of 6 months from the date of termination if it is deemed to be in the best interest of Boone County.
- 2.2.2. **Contract Documents** - The successful bidder(s) shall be obligated to enter into a written contract with the County within 30 days of award on contract forms provided by the County. If bidders desire to contract under their own written agreement, any such proposed agreement shall be submitted in blank with their bid. County reserves the right to modify any proposed form agreement or withdraw its award to a successful bidder if any proposed agreement contains terms and conditions inconsistent with its bid or are unacceptable to county legal counsel.
- 2.3. **MINIMUM TECHNICAL SPECIFICATIONS**
- 2.3.1. **Sign Blanks** – 6", 9", and 12" aluminum
- 2.3.2. **Length** – 24", 30", 36", 42", 48", 54", and 60"
- 2.3.3. **Thickness**
- 2.3.3.1. Lengths up to and including 30" shall be .080 aluminum
- 2.3.3.2. Lengths from 36" to 42" shall be .100 aluminum
- 2.3.3.3. Lengths 48" and up shall be .125 aluminum
- 2.3.4. **Holes** – 5/16" diameter holes shall be pre-drilled before sheeting is applied to signs. The placement of the pre-drilled holes shall be dependent upon the length of the sign. See **Attachment A** for exact hole placement.
- 2.3.5. **Directional Arrows** – The County may request a directional arrow be added to a sign on an 'as needed' basis. This will be indicated on the order at the time of order placement. See **Attachment B** for dimensions of the arrows. The arrow must be reflective yellow in color.
- 2.3.6. **Lettering** – Street name signs for all County maintained roads shall have reflective white lettering, engineering grade, on a green background.
- 2.3.6.1. Street name signs for all privately maintained roads shall have non-reflective black lettering on a reflective white background. An informational placard stating "Private Road" shall have non-reflective black lettering on a reflective white background. See **Attachment C**. This item is identified in Section 4 as line item 4.7.15.
- 2.3.6.2. All numbers and letters shall conform to current industry standards for highway applications and also to specifications in the most current Manual for Uniform Traffic Control Devices (MUTCD). For local roads with a speed limit of 60 miles per hour or less, street name signs shall have six (6") inch white reflective upper case-letters as shown on **Attachment D**. For local roads with a speed limit of 60 miles per hour or greater, street name signs shall have nine (9") inch white reflective upper case-letters as shown on **Attachment E**.
- 2.3.6.3. Any supplementary lettering that indicates the type of street, such as Street, Lane, Circle, or Road, shall have a minimum height of three (3") inches and shall be abbreviated as ST., LN, CIR, and RD. The street coordinates and directional letters (i.e. 2000 NE, 2000 SE, NW, etc.) shall be two (2") inches in height and shall be one-half (1/2") inch from the top of the sign. The street coordinates and

directional letters shall be in the upper right hand corner. If there are two (2) sets of street coordinates, they shall be stacked in the upper right hand corner. The top coordinate shall be for the street named on the sign and the lower coordinate shall denote the cross street.

- 2.3.6.4. There is to be a minimum of five (5”) inches and a maximum of six (6”) inches between each word on multiple word roadway names.
- 2.3.6.5. Length of signs shall be determined by the amount of letters and numbers being placed on the sign blank and in compliance with this section of the bid.
- 2.3.6.6. Corners to be rounded. **See Attachments.**
- 2.3.7. **Deviations** - It is the bidder’s responsibility to submit a bid that meets all mandatory specifications stated within. Because of the variations in manufacturer’s construction, the bidder must compare their product bid with the required listed minimum specifications and identify any deviations. Failure to properly identify deviations may render the bidder’s proposal non-responsive and not capable of consideration for award. Bidders should note that a descriptive brochure of the model bid may not be sufficient or acceptable as proper identification of deviations from the written specifications.
- 2.4. **INVOICING AND PAYMENT** – The contractor must include the following information on each packing list and invoice:
 - Boone County’s specific order number and
 - Street name and corresponding size of each sign
- 2.4.1. In the event the County is in need of specialty signs not outlined on the Response Form, the contractor shall be paid a percentage over cost for the sign blanks as well as an hourly labor rate for sign assembly. The contractor must submit proof of material cost with their invoice.
- 2.5. **REQUIRED SAMPLE** - All bidders **are required** to provide samples of their product at the time of bid response. Exclusion of these samples could deem the bidders response as non-responsive.
- 2.6. **DESIGNEE** - Boone County Public Works Department, 5551 Highway 63 South, Columbia, Missouri 65201.
- 2.7. **BID CLARIFICATION** - Any questions or clarifications concerning bid documents should be addressed to Heather Turner, CPPB, Buyer, 601 E. Walnut, Room 209, Columbia, Missouri 65201. Telephone (573) 886-4392 Fax (573) 886-4390, E-mail: hturner@boonecountymo.org.
- 2.8. **DELIVERY** - Boone County Public Works Department, 5551 Highway 63 South, Columbia, Missouri 65201.
- 2.8.1. **Delivery Terms** - FOB Destination – Inside Delivery, with freight charges fully included and prepaid. The seller pays and bears the freight charges.
- 2.8.2. **Delivery Time:** Preference will be given to vendors supplying signs in the shortest amount of time.
- 2.9. **ORDERING METHOD** – Orders will be requested via e-mail or fax depending upon method available. The successful vendor will be required to confirm receipt of each request.
- 2.10. **NON-EXCLUSIVITY** - The County reserves the right to obtain “like or similar” products of this or other manufacturers, exclusive of this contract, when use of such products is deemed to be in the best interest of the County.

3. Response Presentation and Review

- 3.1. **RESPONSE CONTENT** - In order to enable direct comparison of competing Responses, you must submit your Response in strict conformity to the requirements stated here. Failure to adhere to all requirements may result in your Response being disqualified as non-responsive. All Responses must be submitted using the provided Response Sheet. Every question must be answered and if not applicable, the section must contain "N/A" or "No Bid". Manufacturer's published specifications for the items requested shall be included with the response.
- 3.2. **SUBMITTAL OF RESPONSES** - Responses MUST be received by the date and time noted on the title page under "Bid Submission Information and Deadline". **Note: Bid Submission and Bid Opening times are different. NO EXCEPTIONS.** We are not responsible for late or incorrect deliveries from the US Postal Service or any other mail carrier.
 - 3.2.1. **Submittal Package** - Submit, to the location specified on the title page, **three (3) complete copies** of your Response in a single sealed envelope, clearly marked on the outside with your company name and return address, the proposal number and the due date and time.
 - 3.2.2. **Advice of Award** - A Bid Tabulation of responses received as well as Award status can be viewed at www.showmeboone.com.
- 3.3. **BID OPENING** - On the date and time and at the location specified on the title page under "Bid Opening", all Responses will be opened in public. Brief summary information from each will be read aloud.
 - 3.3.1. **Removal from Vendor Database** - If any prospective Bidder currently in our Vendor Database to whom the Bid was sent elects not to submit a Response and fails to reply in writing stating reasons for not bidding, that Bidder's name may be removed from our database. Other reasons for removal include unwillingness or inability to show financial responsibility, reported poor performance, unsatisfactory service, or repeated inability to meet delivery requirements.
- 3.4. **RESPONSE CLARIFICATION** - We reserve the right to request additional written or oral information from Bidders in order to obtain clarification of their Responses.
 - 3.4.1. **Rejection or Correction of Responses** - We reserve the right to reject any or all Responses. Minor irregularities or informalities in any Response which are immaterial or inconsequential in nature, and are neither affected by law nor at substantial variance with Bid conditions, may be waived at our discretion whenever it is determined to be in the County's best interest.
- 3.5. **EVALUATION PROCESS** - Our sole purpose in the evaluation process is to determine from among the Responses received which one is best suited to meet the County's needs at the lowest possible cost. Any final analysis or weighted point score does not imply that one Bidder is superior to another, but simply that in our judgment the Contractor selected appears to offer the best overall solution for our current and anticipated needs at the lowest possible cost.
 - 3.5.1. **Method of Evaluation** - We will evaluate submitted responses in relation to all aspects of this Bid.
 - 3.5.2. **Acceptability** - We reserve the sole right to determine whether goods and/or services offered are acceptable for our use.
 - 3.5.3. In the event of a discrepancy between a unit price and an extended line item price, the unit price shall govern.
 - 3.5.4. **Endurance of Pricing** - Your pricing must be held until contract execution or 60 days, whichever comes first.
 - 3.5.5. Boone County reserves the right to reject all bids. Boone County reserves the right to waive informalities in bids.

4. Response Form

4.1. Company Name: _____

4.2. Address: _____

4.3. City/Zip: _____

4.4. Phone Number: _____

4.5. Fax Number: _____

4.6. Federal Tax ID: _____

4.6.1. () Corporation

() Partnership - Name _____

() Individual/Proprietorship - Individual Name _____

() Other (Specify) _____

4.7. Pricing							
			Double Sided			Single Sided	
Item #	Size	Aluminum Gauge	Est Qty	Unit Price	Total Price	Est Qty	Unit Price
4.7.1.	24"x9"	.080	5	\$ _____	\$ _____	1	\$ _____
4.7.2.	24"x12"	.080	5	\$ _____	\$ _____	1	\$ _____
4.7.3.	30"x9"	.080	50	\$ _____	\$ _____	1	\$ _____
4.7.4.	30"x12"	.080	10	\$ _____	\$ _____	1	\$ _____
4.7.5.	36"x9"	.100	50	\$ _____	\$ _____	1	\$ _____
4.7.6.	36"x12"	.100	5	\$ _____	\$ _____	1	\$ _____
4.7.7.	42"x9"	.100	60	\$ _____	\$ _____	1	\$ _____
4.7.8.	42"x12"	.100	10	\$ _____	\$ _____	1	\$ _____
4.7.9.	48"x9"	.125	40	\$ _____	\$ _____	1	\$ _____
4.7.10.	48"x12"	.125	10	\$ _____	\$ _____	1	\$ _____
4.7.11.	54"x9"	.125	50	\$ _____	\$ _____	1	\$ _____
4.7.12.	54"x12"	.125	5	\$ _____	\$ _____	1	\$ _____
4.7.13.	60"x9"	.125	30	\$ _____	\$ _____	1	\$ _____
4.7.14.	60"x12"	.125	20	\$ _____	\$ _____	1	\$ _____

4.7.15.	18"x4"	.080				15	\$ _____
4.7.16.	Total Double Sided				\$ _____		
4.7.17.	Total Single Sided						\$ _____
4.7.18.	Directional Arrows (Add-On Cost Per Arrow)				\$ _____ each		

NOTE: The quantities listed above are for cost evaluation purposes only and do not represent actual or intended usage.

4.9. Percentage over cost for sign blank sizes not noted above: _____% over cost

4.10. Hourly labor rate for specialty sign assembly: \$ _____/hour

4.11. Warranty period against fading, chipping, or peeling: _____

4.12. Maximum Percentage Increase for _____% 2nd Year; _____% 3rd Year.

4.13. **Delivery After Receipt of Order:** _____

4.14. **The undersigned offers to furnish and deliver the articles or services as specified at the prices and terms stated and in strict accordance with the specifications, instructions and general conditions of bidding which have been read and understood, and all of which are made part of this order.**

4.14.1. Authorized Representative (Sign By Hand):

4.14.2. Type or Print Signed Name:

4.14.3. Today's Date: _____

4.15. Will you honor the submitted prices for purchase by other entities in Boone County who participate in cooperative purchasing with Boone County, Missouri?

_____ Yes _____ No

ATTACHMENT A

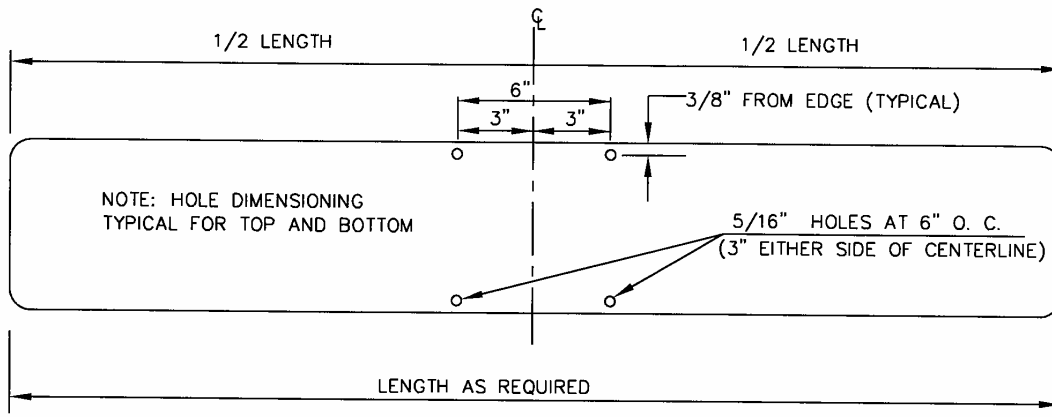

LOCATION OF MOUNTING HOLES
FOR SIGNS LESS THAN 48" LONG

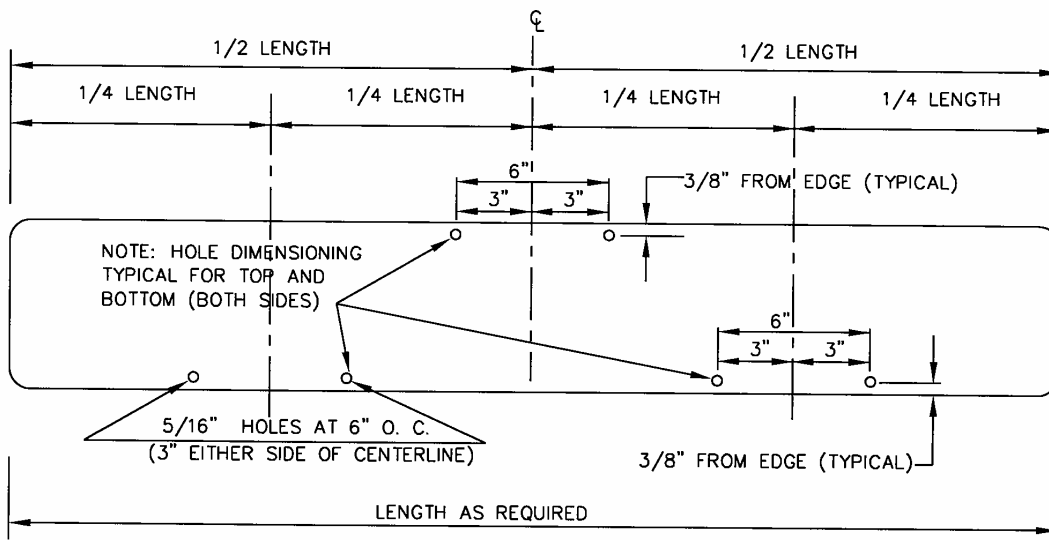

LOCATION OF MOUNTING HOLES
FOR SIGNS EQUAL TO OR GREATER THAN 48" LONG

ATTACHMENT B

03/07/2006 10:45 FAA 5738751602

→ PURCHASING

001

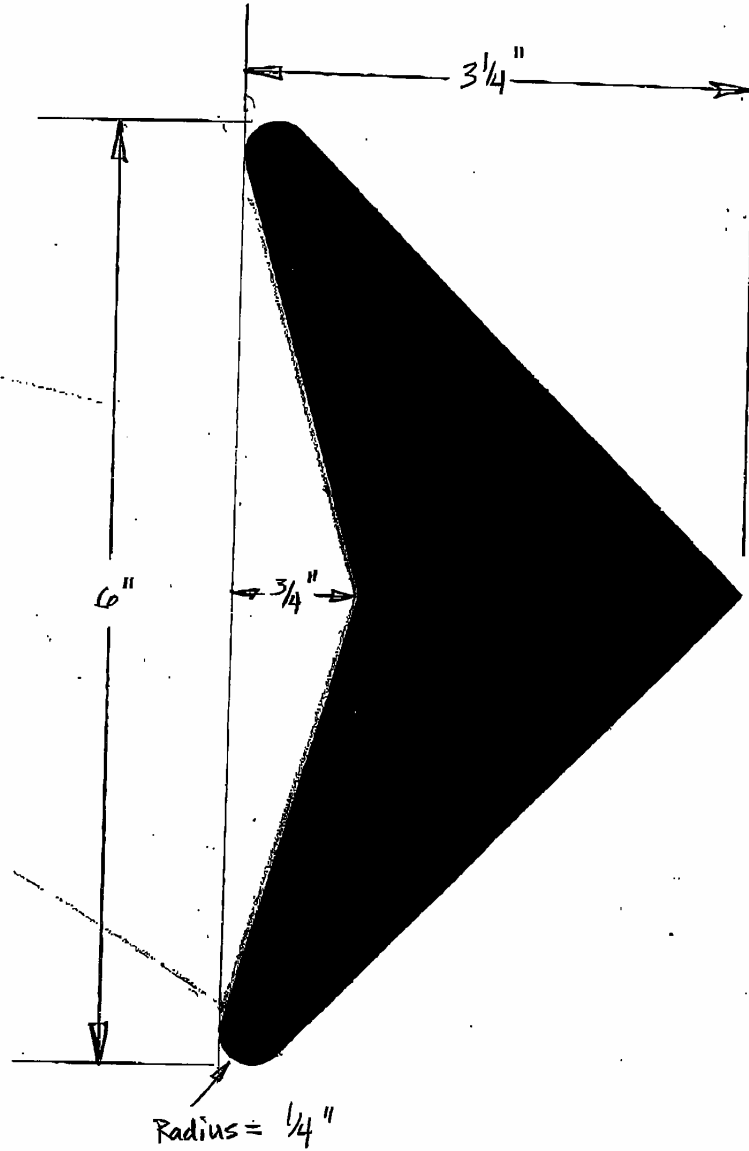

ATTACHMENT C

02/25/2003 11:44 FAX

→ PURCHASING

003

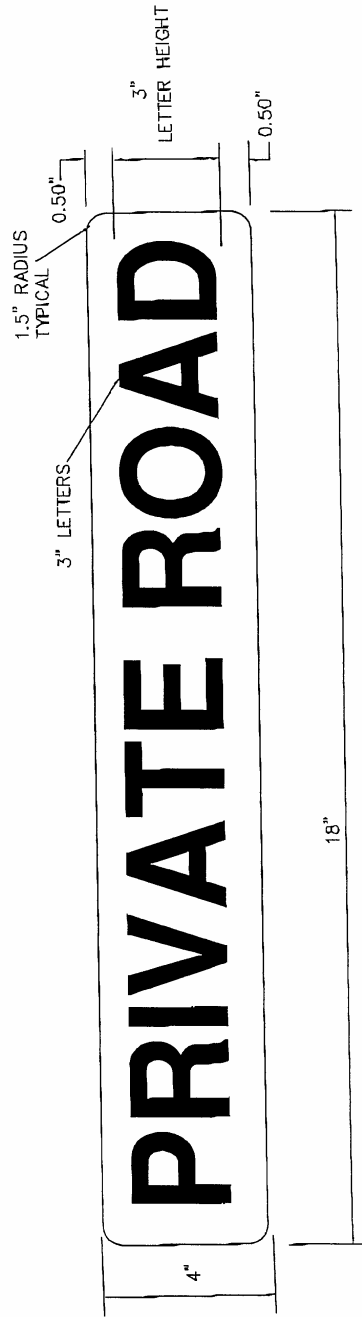

LOCATION OF LETTERS
FOR PRIVATE ROADS

ATTACHMENT D

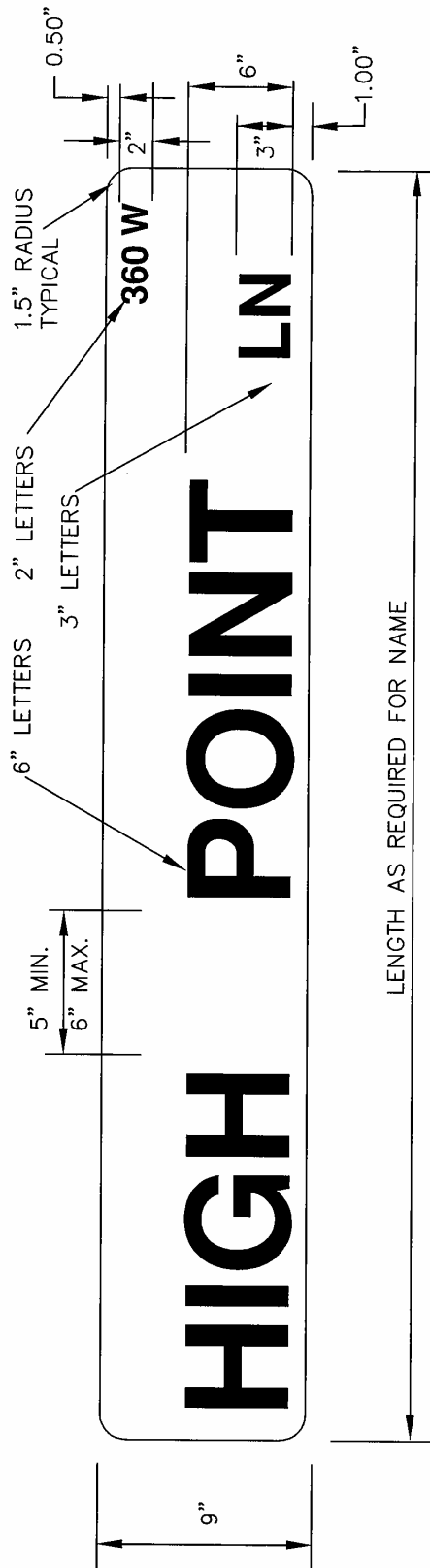

LOCATION OF LETTERS
FOR INTERSECTIONS WHERE
SPEED LIMIT IS LESS THAN 60 MPH

ATTACHMENT E

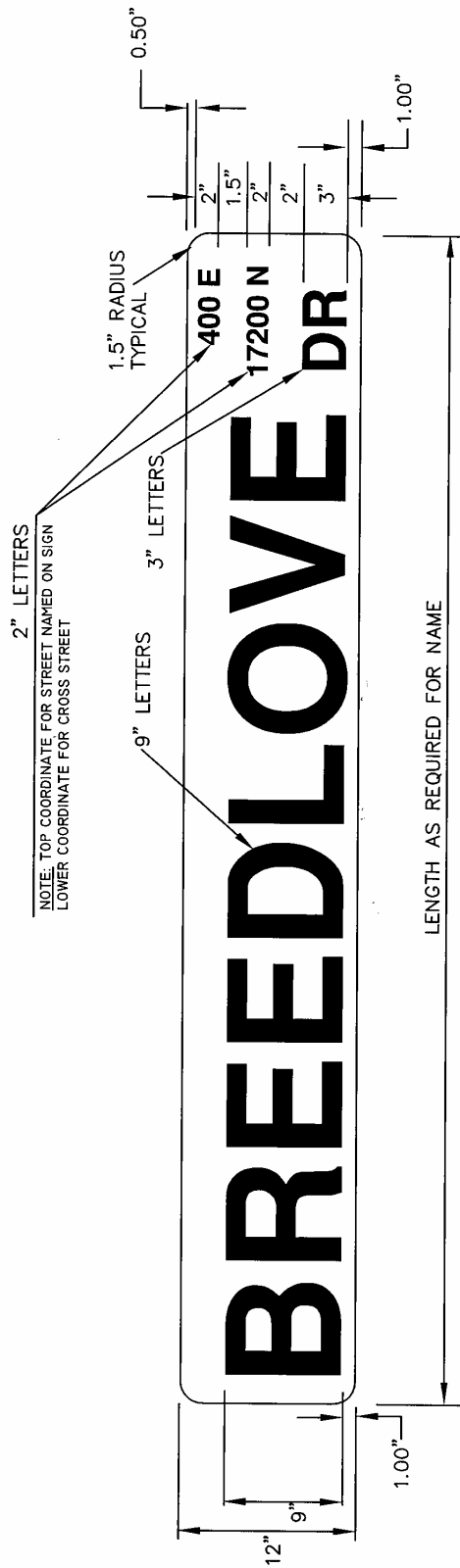

LOCATION OF LETTERS
FOR INTERSECTIONS WHERE
SPEED LIMIT IS 60 MPH OR GREATER



Standard Terms and Conditions

Boone County Purchasing

601 E. Walnut, Room 209

Columbia, MO 65201

Heather Turner, Buyer

Phone: (573) 886-4392 – Fax: (573) 886-4390

1. Responses shall include all charges for packing, delivery, installation, etc., (unless otherwise specified) to the Boone County Department identified in the Request for Bid and/or Proposal.
2. The Boone County Commission has the right to accept or reject any part or parts of all bids, to waive technicalities, and to accept the offer the County Commission considers the most advantageous to the County. Boone County reserves the right to award this bid on an item by item basis, or an “all or none” basis, whichever is in the best interest of the County.
3. Bidders must use the bid forms provided for the purpose of submitting bids, must return the bid and bid sheets comprised in this bid, give the unit price, extended totals, and sign the bid.
4. When products or materials of any particular producer or manufacturer are mentioned in our specifications, such products or materials are intended to be descriptive of type or quality and not restricted to those mentioned.
5. Do not include Federal Excise Tax or Sales and Use Taxes in bid process, as law exempts the County from them.
6. The delivery date shall be stated in definite terms, as it will be taken into consideration in awarding the bid.
7. The County Commission reserves the right to cancel all or any part of orders if delivery is not made or work is not started as guaranteed. In case of delay, the Contractor must notify the Purchasing Department.
8. In case of default by the Contractor, the County of Boone will procure the articles or services from other sources and hold the Bidder responsible for any excess cost occasioned thereby.
9. Failure to deliver as guaranteed shall disqualify Bidder from future bidding.
10. Prices must be as stated in units of quantity specified, and must be firm. Bids qualified by escalator clauses may not be considered unless specified in the bid specifications.
11. No bid transmitted by fax machine will be accepted.
12. The County of Boone, Missouri expressly denies responsibility for, or ownership of any item purchased until same is delivered to the County and is accepted by the County.
13. In the event of a discrepancy between a unit price and an extended line item price, the unit price shall govern.



“No Bid” Response Form

Boone County Purchasing
601 E. Walnut, Room 209
Columbia, MO 65201

Heather Turner, CPPB, Buyer
(573) 886-4392– Fax: (573) 886-4390

“NO BID RESPONSE FORM”

**NOTE: COMPLETE AND RETURN THIS FORM ONLY IF YOU DO NOT WANT TO
SUBMIT A BID**

If you do not wish to respond to this bid request, but would like to remain on the Boone County vendor list for this service/commodity, please remove form and return to the Purchasing Department by mail or fax.

If you would like to FAX this “No Bid” Response Form to our office, the FAX number is (573) 886-4390.

Bid: 22-28MAR06

Business Name: _____

Address: _____

Telephone: _____

Contact: _____

Date: _____

Reason(s) for not bidding:

