

**CONTRACT DOCUMENTS
BOONE COUNTY, MISSOURI
BOONE COUNTY FAIRGROUND PAVEMENT MAINTENANCE # 9755
BID NO: 26-17APR03**

ADDENDUM #1

This addendum is issued in accordance with the Instructions to Bidders and is hereby incorporated into and made a part of the Contract Documents.

Bidders are reminded that receipt of this addendum must be acknowledged and submitted with the attached **Acknowledgment of Addendum Form (on page 5.4)**.

Drawings and specifications for the above noted project and the work covered thereby are herein modified as follows, and except as set forth herein, otherwise remain unchanged and in full force and effect:

PROJECT MANUAL CLARIFICATION:

1. Specification Section 02951: A detail is provided to depict the anticipated work required to repair a pothole / construct a small pavement patch.

PLEASE NOTE: This does not change the bid opening date, bids are due at the Boone County Purchasing Office, Johnson Building, 601 E. Walnut, 2nd Floor, Columbia, Missouri, 65201-7731 until 1:15 p.m. on April 17, 2003.

The bid is scheduled to be opened after 1:30 p.m. at the Boone County Purchasing Office, Johnson Building 601 E. Walnut, 2nd Floor Columbia, Missouri 65201-7731

BIDDER has examined copies of Addendum #1 to Boone County Fairground Pavement Maintenance Construction Bid Request number 26-17Apr03, receipt of which is hereby acknowledged:

Company Name _____

Address _____

Phone Number _____

Authorized Representative _____



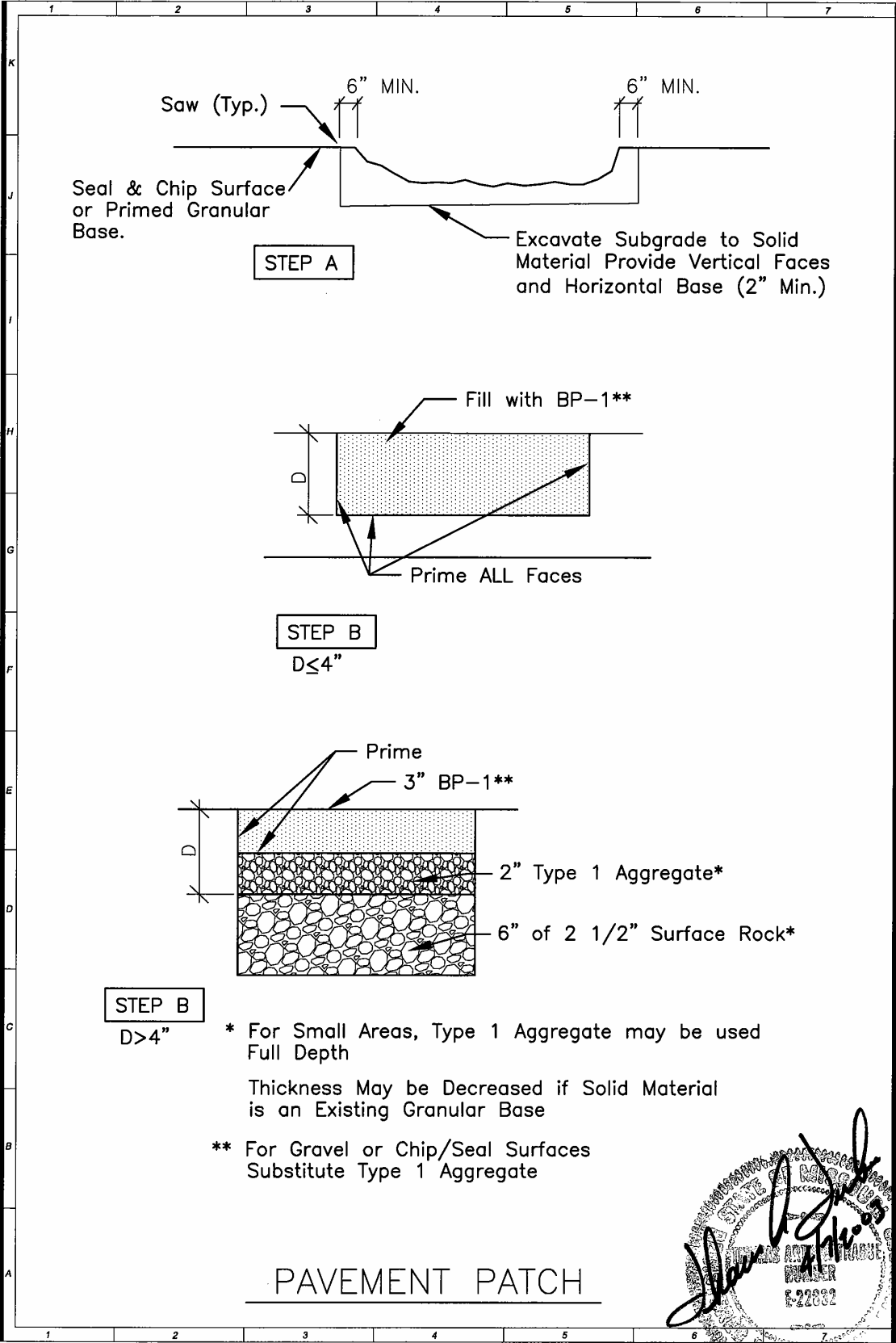

* For Small Areas, Type 1 Aggregate may be used Full Depth
 Thickness May be Decreased if Solid Material is an Existing Granular Base

** For Gravel or Chip/Seal Surfaces Substitute Type 1 Aggregate

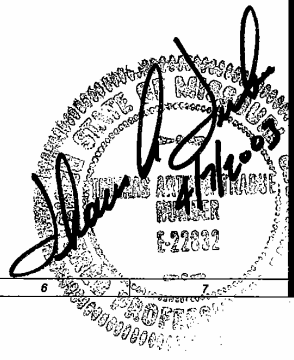

County of Boone
Fairgrounds Pavement Maintenance
 Pavement Patch

THHinc
 TRABUE, HANSEN & HINSHAW, INC.
 CONSULTING ENGINEERS
 PHONE (573) 814-1568
 FAX (573) 814-1128
 EMAIL: info@thhinc.com
 1801 PENNSYLVANIA DR.
 COLUMBIA, MO 65202

DWG. **XX**
 Plotted 3/19/2003
 THHinc # 1815