

CERTIFIED COPY OF ORDER

March Session of the January Adjourned

Term. 20 17

STATE OF MISSOURI }
County of Boone } ea.

In the County Commission of said county, on the 16th day of March 20 17
the following, among other proceedings, were had, viz:

Now on this day the County Commission of the County of Boone does hereby recognize March, 2017 as Developmental Disability Awareness Month.

Done this 16th day of March, 2017.

ATTEST:



Wendy S. Noren
Clerk of the County Commission

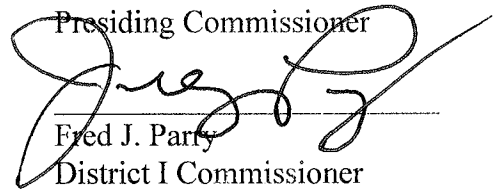

Daniel K. Atwill
Presiding Commissioner

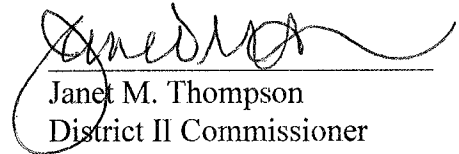

Fred J. Party
District I Commissioner



Janet M. Thompson
District II Commissioner

**PROCLAMATION RECOGNIZING
MARCH 2017 AS DEVELOPMENTAL DISABILITY
AWARENESS MONTH**

- Whereas,* more than 5 million people nationwide have developmental disabilities, including over 100,000 Missourians; and
- Whereas,* individuals with developmental disabilities share with all individuals the desire to achieve personal success through education, meaningful work and family and community involvement; and
- Whereas,* individuals with developmental disabilities, along with their families, friends, neighbors and co-workers, recognize the importance of focusing on the abilities of all people and encourage others to do the same; and
- Whereas,* the most effective way to increase this focus is through everyone's active participation in community life and openness to each individual's contribution; and
- Whereas,* opportunities for citizens with developmental disabilities to participate fully must be fostered in our community through a commitment to recognizing the strengths and values of every person and the capability of every person to make important contributions to our community if given the opportunity; and
- Whereas,* we encourage all citizens to support opportunities for individuals with developmental disabilities in our community, which includes full access to education, housing, employment and recreational activities.
- Therefore,* we, the Boone County Commission, do hereby proclaim March 2017 as Developmental Disabilities Awareness Month in the County of Boone, Missouri, recognizing the importance of individuals of all abilities to our community and that our community is stronger when everyone participates.

IN TESTIMONY WHEREOF, this 16th day of March, 2017.

Daniel K. Atwill, Presiding Commissioner

Fred J. Parry, District I Commissioner

Janet M. Thompson, District II Commissioner

ATTEST:

Wendy S. Noren, County Clerk

126-2017

CERTIFIED COPY OF ORDER

STATE OF MISSOURI }
County of Boone } ea.

March Session of the January Adjourned

Term. 20 17

In the County Commission of said county, on the 16th day of March 20 17

the following, among other proceedings, were had, viz:

Now on this day the County Commission of the County of Boone does hereby approve the attached Contract Amendment Number One to 13-23FEB16 – HVAC Plumbing and Valve Replacement for the Boone County Sheriff’s Department.

The terms of the amendment are stipulated in the attached Amendment. It is further ordered the Presiding Commissioner is hereby authorized to sign said Contract Amendment Number One regarding HVAC Plumbing and Valve Replacement for the Sheriff’s Department.

Done this 16th day of March, 2017.

ATTEST:

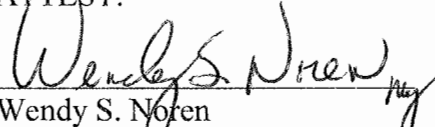
Wendy S. Noren
Clerk of the County Commission

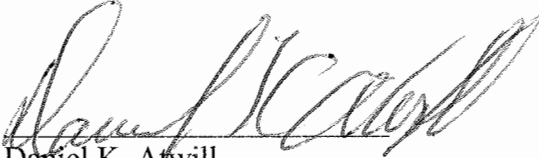
Daniel K. Atwill
Presiding Commissioner

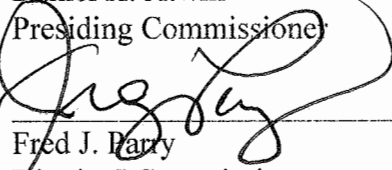
Fred J. Parry
District I Commissioner

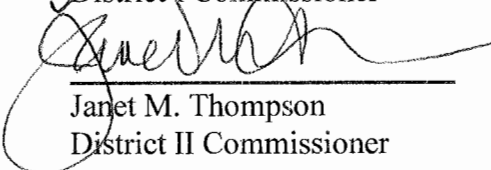
Janet M. Thompson
District II Commissioner

126-2016

Boone County Purchasing

Jacob M. Garrett
Buyer



613 E. Ash St., Room 111
Columbia, MO 65201
Phone: (573) 886-4393
Fax: (573) 886-4390

MEMORANDUM

TO: Boone County Commission
FROM: Jacob M. Garrett
DATE: March 8, 2017
RE: Amendment #1 to contract: 13-23FEB16 – HVAC Plumbing and Valve Replacement for the Boone County Sheriff Department

Request for Bid 13-23FEB16 – HVAC Plumbing and Valve Replacement for the Boone County Sheriff Department was awarded in Commission on March 17, 2017, commission order 133-2016 to J. Louis Crum Corporation of Columbia, Missouri for \$33,155.

The attached amendment includes four change orders for a total increase of \$5,515.04.

Change Order 1: \$2,913.77 – replace heating water valves and piping
Change Order 2: \$715.77 – repair leaks in the heating water
Change Order 3: \$1,079.25 – repair leak on heating coil
Change Order 4: \$806.25 – ductwork and piping additional insulation

Invoices will be paid from department 6200 – Capital Repairs & Replacements, account 60110 – Major Building Repairs.

cc: Bid File
Gary German / Leasa Quick, Sheriff Department
Doug Coley, Facilities Maintenance

**CONTRACT AMENDMENT NUMBER ONE
PURCHASE AGREEMENT FOR
13-23FEB16 – HVAC PLUMBING AND VALVE REPLACEMENT – BOONE COUNTY
SHERIFF DEPARTMENT**

The Purchase Agreement dated March 17, 2016 made by and between Boone County, Missouri and J. Louis Crum Corporation. for and in consideration of the performance of the obligations of the parties set forth herein, is amended as follows:

1. Contract **13-23FEB16** is being amended by adding the following Change Orders #1- #4 requested from J. Louis Crum Corporation.
 - Change Order #1 - \$2,913.77
 - Change Order #2 - \$715.77
 - Change Order #3 - \$1,079.25
 - Change Order #4 - \$806.25

TOTAL - \$5,515.04

IN WITNESS WHEREOF the parties through their duly authorized representatives have executed this agreement on the day and year first above written.

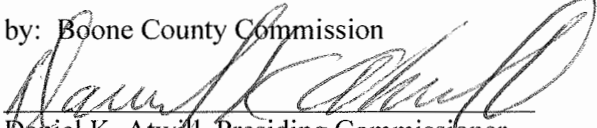

J. LOUIS CRUM CORPORATION
 by 
 title MANAGER

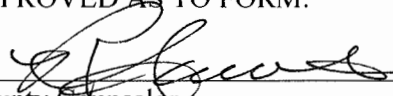
BOONE COUNTY, MISSOURI
 by: Boone County Commission

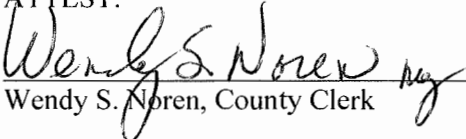
 Daniel K. Atwill, Presiding Commissioner

APPROVED AS TO FORM:

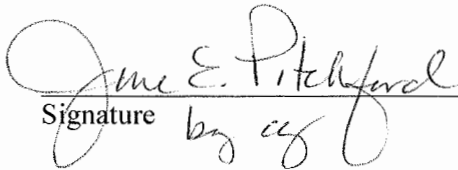
 County Counselor

ATTEST:

 Wendy S. Noren, County Clerk

AUDITOR CERTIFICATION
 In accordance with RSMo 50.660, I hereby certify that a sufficient unencumbered appropriation balance exists and is available to satisfy the obligation(s) arising from this contract. (Note: Certification of this contract is not required if the terms of this contract do not create a measurable county obligation at this time.)

<u></u>	<u>3/8/17</u>	<u>6200/60110</u>
Signature <u>by </u>	Date	Appropriation Account

J. Louis Crum Corporation
Mechanical Contractors Since 1924
1312 N. Creasy Springs Rd - Columbia, MO 65202
Phone: (573) 443-2488 - Email: Accounts@JLCrum.com

12/30/2016

201609-2

To: Boone County Sheriff's Depart (4127.3)
Corrections
2121 County Dr.
Columbia, MO 65202-

For Job: 201609
Boone Co Sheriff Dept.-Valve Replacement
HVAC Plumbing & Valve Replacement
Per Purchase Order No. 2016000090

AR Code	Quantity U/M	Price	Amount
Contract Balance		\$11,454.00	
Change Order #1		\$2,913.77	
Change Order #2		\$ 715.77	
Change Order #3		\$1,079.25	
		\$0.0000	
		0.0000	16,162.79
		Tax:	0.00

4708.79

Invoice Totals

Gross	
Retention	0.00
Tax	0.00
TOTAL DUE	16,162.79

J Louis Crum Corporation

Mechanical Contractors Since 1924

1312 N Creasy Springs Rd
Columbia, Missouri, 65202
(573) 443-2488

Heating Air Conditioning Plumbing
Commercial Refrigeration
email: mailbox@jlcrum.com

Boone County Jail #201609

Change order request #1

Description

BJ and Dave replaced heating water valves and piping

Subcontractors

Subcontractor		\$	-
	7.5% Crum O&P	\$	-
Subcontractor Subtotal		\$	-

Materials and Equipment

2 1/2" Sch 40 Blk Pipe	10 ft	\$ 5.14 per ft	\$ 51.40
2 1/2" Vic Flanges	6 ea	\$ 66.29	\$ 397.74
2 1/2" Vic 90's	6 ea	\$ 20.30	\$ 121.80
2 1/2" Vic 45	1 ea	\$ 20.30	\$ 20.30
2 1/2" Vic Coup	18 ea	\$ 19.67	\$ 354.06
2 1/2" Butterfly Valves	2 ea	\$ 132.45	\$ 264.90
2 1/2" BFV Bolt Sets	2 ea	\$ 7.29	\$ 14.58
4" Vic coup	1 ea	\$ 31.73	\$ 31.73
4" Vic Cap	.1 ea	\$ 18.52	\$ 18.52
Total Materials			<u>\$ 1,275.03</u>

Direct Labor

Pipefitter	17 hrs	\$ 74.04 per hr	\$ 1,258.68
------------	--------	-----------------	-------------

Direct Subtotal	\$ 2,533.71
-----------------	-------------

15% O&P	\$ 380.06
---------	-----------

Subcontractor Total with Crum O&P	\$ -
-----------------------------------	------

Total	<u><u>\$ 2,913.77</u></u>
--------------	---------------------------

Please adjust our contract by the addition of \$2,913.77 for the work to be performed.

Sincerely,



Matt Haller
Project Manager
J. Louis Crum Corporation

J Louis Crum Corporation

Mechanical Contractors Since 1924

1312 N Creasy Springs Rd
Columbia, Missouri, 65202
(673) 443-2488

Heating Air Conditioning Plumbing
Commercial Refrigeration
email: mailbox@jlcum.com

Boone County Jail #201609

May 26, 2016

Change order request #2

Description

BJ Bax repaired leaks in the heating water.

Subcontractors

Subcontractor			\$	-
		7.5% Crum O&P	\$	-
		Subcontractor Subtotal	\$	-

Materials and Equipment

3"	Victaulic 90's	1 ea	\$ 35.91	\$ 35.91
3"	Victaulic Coupling	7 ea	\$ 22.59	\$ 158.13
4"	Victaulic Coupling	3 ea	\$ 31.73	\$ 95.19
	Total Materials			<u>\$ 289.23</u>

Direct Labor

Pipefitter	4.5 hrs	\$ 74.04 per hr	\$ 333.18
		Direct Subtotal	\$ 622.41
		15% O&P	\$ 93.36
		Subcontractor Total with Crum O&P	\$ -
		Total	<u>\$ 715.77</u>

Please adjust our contract by the addition of \$715.77 for the work to be performed.

Sincerely,

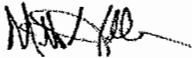

Matt Haller
Project Manager
J. Louis Crum Corporation

✶✶

J Louis Crum Corporation

Mechanical Contractors Since 1924

1312 N Creasy Springs Rd
Columbia, Missouri, 65202
(573) 443-2488

Heating Air Conditioning Plumbing
Commercial Refrigeration
email: mailbox@jlcrum.com

Boone County Jail #201609

1256
60100

Change order request #3

Description

Repair Leak on Heating Coil

Subcontractors

Subcontractor X

	\$	-
7.5% Crum O&P	\$	-
Subcontractor Subtotal	\$	-

Materials and Equipment

Silver solder/Gas	\$	20.00
Air Compressor	\$	30.00
	\$	50.00

Direct Labor

Pipefitter	12 hrs	\$ 74.04 per hr	\$ 888.48
Plumber	0 hrs	\$ 72.41 per hr	\$ -
Sprinkler Fi	0 hrs	\$ 68.73 per hr	\$ -
			\$ 888.48

Direct Subtotal	\$	938.48
15% O&P	\$	140.77
Subcontractor Total with Crum O&P	\$	-
Total	\$	1,079.25

Please adjust our contract by the addition of \$1,079.25 for the work to be performed.

Sincerely,



Matt Haller
Project Manager
J. Louis Crum Corporation

J. LOUIS CRUM CORPORATION

Heating - Air Conditioning - Plumbing - Commercial Refrigeration

1312 N Creasy Springs Road, Columbia, Missouri 65202

Ph (573) 443-2488 Fax (573) 443-3469

To: Boone County Jail

Date: 12/30/16
Re: Billing for Contract and 3 CO's
CO #4 Pending insulation
JLC Job # 201609

We are sending to you:

1

Copy of contract billing including 3 of 4 Change orders
Change Order #4 pending (insulation)

Transmitted :

- For your use
 For Approval
 As Requested

- For your files
 Approved as noted
 Approved

Please return _____ approved copy.

Remarks: Change Order #4 Pending Insulation work being preformed 1/4/17

Copies to:

J. Louis Crum Corporation

By: Matt Hallen

J. Louis Crum Corporation

Mechanical Contractors Since 1924

1312 N. Creasy Springs Rd - Columbia, MO 65202
Phone: (573) 443-2488 - Email: Accounts@JLCrum.com

02/17/2017

201609-3

To: Boone County Sheriff's Depart (4127.3)
Corrections
2121 County Dr.
Columbia, MO 65202-

For Job: 201609
Boone Co Sheriff Dept.-Valve Replacement
HVAC Plumbing & Valve Replacement
Per Purchase Order No. 2016000090

AR Code	Quantity U/M	Price	Amount
	Change Order #4	\$0.0000	806.25
		Tax:	0.00

Invoice Totals

Gross	
Retention	0.00
Tax	0.00
TOTAL DUE	806.25

J Louis Crum Corporation

Mechanical Contractors Since 1924

1312 N Creasy Springs Rd
Columbia, Missouri, 65202
(573) 443-2488

Heating Air Conditioning Plumbing
Commercial Refrigeration
email: mailbox@jlcum.com

Date 2/17/17

Boone County Jail #201609

Change order request #4

Description

Ductwork and Piping additional Insulation

Subcontractors

Zumalt Insulation

	\$	750.00
7.5% Crum O&P	\$	56.25
Subcontractor Subtotal	\$	806.25

Materials and Equipment

Direct Labor

Pipefitter	0 hrs	per hr	\$	-
Plumber	0 hrs	per hr	\$	-
Sprinkler Fi	0 hrs	per hr	\$	-

Direct Subtotal	\$	-
15% O&P	\$	-
Subcontractor Total with Crum O&P	\$	806.25
Total	\$	806.25

Please adjust our contract by the addition of \$806.25 for the work to be performed.

Sincerely,



Matt Haller
Project Manager
J. Louis Crum Corporation

127 -2017

CERTIFIED COPY OF ORDER

STATE OF MISSOURI }
County of Boone } ea.

March Session of the January Adjourned

Term. 20 17

In the County Commission of said county, on the 16th day of March 20 17

the following, among other proceedings, were had, viz:

Now on this day the County Commission of the County of Boone does hereby approve the attached Contract Amendment Number Two to 138AN-TISA2013 – Telephone System for the Emergency Communication Center.

The terms of the amendment are stipulated in the attached Amendment. It is further ordered the Presiding Commissioner is hereby authorized to sign said Contract Amendment Number Two.

Done this 16th day of March, 2017.

ATTEST:

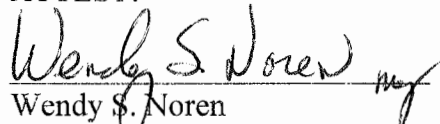

Wendy S. Noren
Clerk of the County Commission

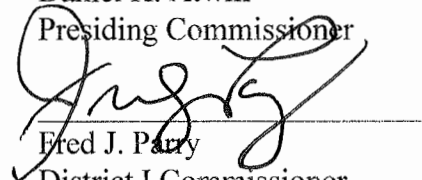

Daniel K. Atwill
Presiding Commissioner

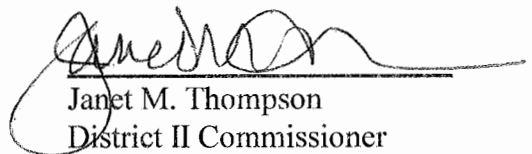

Fred J. Parry
District I Commissioner



Janet M. Thompson
District II Commissioner

127-2017

Boone County Purchasing

Melinda Bobbitt, CPPB
Director of Purchasing



613 E. Ash St, Room 110
Columbia, MO 65201
Phone: (573) 886-4391
Fax: (573) 886-4390

MEMORANDUM

TO: Boone County Commission
FROM: Melinda Bobbitt, CPPB
DATE: March 8, 2017
RE: Amendment Number Two – 138AN-TISA2013 – Telephone System for the Emergency Communication Center

Contract *138AN-TISA2013 – Telephone System for the Emergency Communication Center* was approved by commission for award to Centurylink Communications, LLC on June 23, 2016, commission order 248-2016. Per Aron Gish, Boone County Information Technology Director, this amendment is needed to purchase circuits that are needed to complete the 911 Viper Phone system install.

Invoice will be paid from departments 4101 – ECC Radio & Technology, account 71231 – Owner Costs. Monthly charges are as follows:

Centralia Police	\$660 x 11 = \$7,260
UM Police	\$525 x 11 = \$5,775
Boone County 911	\$875 x 11 = \$9,625
TOTAL	\$22,660 for 2017

cc: Aron Gish, IT
Contract File

138AN-TISA-2013-0416
Amendment #2

Commission order: 127-2017
Date: 3-16-17

AMENDMENT TO
CENTURYLINK® LOYAL ADVANTAGE®
MICTA MEMBER PARTICIPATION CONTRACT

THIS AMENDMENT NO. Two (this "Amendment") by and between **CenturyLink Communications, LLC f/k/a Qwest Communications Company, LLC** ("CenturyLink") and **Boone County** ("Customer" or "Member"), hereby amends the CenturyLink Loyal Advantage Agreement, or Qwest Loyal Advantage Agreement, as applicable for this MiCTA Member, CenturyLink Contract ID: 1039681, as may have been previously amended (the "Agreement"). For an interim period of time until all work is completed to update the Service Exhibits, Tariffs and other terms and conditions incorporated by attachment or reference into this Amendment, all references to Qwest Communications Company, LLC mean CenturyLink Communications, LLC. Except as set forth in this Amendment, capitalized terms will have the definitions assigned to them in the Agreement. All references to "Qwest Loyal Advantage" or "QLA" are hereby replaced with "CenturyLink Loyal Advantage."

CenturyLink and Member wish to amend the Agreement as follows:

1. **Term.** Member's existing Term in the Agreement will remain in effect.
2. **Addition of Services.** The Service Exhibit(s) and Offer Attachment(s) listed below are attached and incorporated into the Agreement to describe the addition of new Service(s) to the Agreement.

- **CenturyLink IQ® Data Bundle Offer Attachment**

The definition of Services in the Agreement will include the Services in the Service Exhibits and Offer Attachments attached to this Amendment.

2. **Existing Services.** Member's existing Services as set forth in the Agreement will remain in effect.
3. **Pricing.** The monthly recurring charges ("MRCs"), nonrecurring charges ("NRCs"), and/or usage charges applicable to the Services based upon the Term will be those set forth in the MiCTA Master Agreement and available on the MiCTA Web site for Members located at www.mictatech.org ("MiCTA Rate Schedule"). Pricing for new Services under this Amendment will become effective at CenturyLink's earliest opportunity, but in no event later than the second full billing cycle following the Amendment Effective Date.
4. **Modifications.** To the extent that the following provisions are not already in the Agreement or in a previous amendment, they are added through this Amendment. The Agreement is amended as follows:

4.1 General.

(a) Member will not pay for the Services with funds obtained through the American Recovery and Reinvestment Act (or ARRA) or other similar stimulus grants or loans that would obligate CenturyLink to provide certain information or perform certain functions unless each of those functions and obligations is explicitly identified and agreed to by the parties in this Agreement or in an amendment to this Agreement.

(b) Member may access its invoices and choose paperless invoices online through CenturyLink Control Center located at controlcenter.centurylink.com. If Member does not choose paperless invoices through Control Center, CenturyLink may in its discretion assess a \$15 MRC for each full paper invoice provided to Member or a \$2 MRC for each summary/remit only (where available) paper invoice provided to Member. Those charges will not apply to an invoice that is not available through Control Center. Member's payments to CenturyLink must be in the form of electronic funds transfer (via wire transfer or ACH), cash payments (via previously-approved CenturyLink process only), or paper check. CenturyLink reserves the right to charge administrative fees when Member's payment preferences deviate from CenturyLink's standard practices.

(c) CenturyLink will provide Service if: (i) there is a valid, accurate, and complete Order Form submitted by Member; (ii) adequate capacity is available; and (iii) CenturyLink accepts the Order Form.

(d) CenturyLink may change features or functions of its Services; for material changes that are adverse to Customer, CenturyLink will provide 30 days prior written notice, but may provide a shorter notice period if the change is based on Regulatory Activity.

(e) If Services are provided pursuant to a Tariff, RSS, or ISS, as described in the applicable Service Exhibits, the order of precedence will apply in the following descending order of control: Tariff, Service Exhibit, Agreement, RSS, ISS, and Order Form.

(f) CenturyLink's Information Services Schedule ("ISS"), Rates and Services Schedules ("RSS") and Tariff (which includes CenturyLink state tariffs, price lists, price schedules, administrative guidelines, catalogs, and rate and term schedules) are posted at the following links and are incorporated by this reference:

- The ISS is located at http://www.centurylink.com/tariffs/clc_info_services.pdf
- The International RSS is located at http://www.centurylink.com/tariffs/fcc_clc_ixc_rss_no_2.pdf

127-2017

**AMENDMENT TO
CENTURYLINK® LOYAL ADVANTAGE®
MiCTA MEMBER PARTICIPATION CONTRACT**

- The Interstate RSS is located at http://www.centurylink.com/tariffs/fcc_clc_ixc_rss_no_3.pdf
- The Tariff is located at <http://www.centurylink.com/tariffs>

(g) The Definitions Section is amended to include the following:

"Detailed Description" is defined in the Select Advantage Service Exhibit.

"Regulatory Activity" is a regulation or ruling, including modifications thereto, by any regulatory agency, legislative body or court of competent jurisdiction. CenturyLink reserves the right to amend, change, withdraw or file additional Tariffs or RSS in its sole discretion, with such updated Tariffs or RSS effective upon posting or upon fulfillment of any necessary regulatory requirements.

4.2 CPNI. The following CPNI Section is added to the Agreement:

(a) "CPNI" means Customer Proprietary Network Information, which includes confidential account, usage, and billing-related information about the quantity, technical configuration, type, destination, location, and amount of use of a customer's telecommunications services. CPNI reflects the telecommunications products, services, and features that a customer subscribes to and the usage of such services, including call detail information appearing in a bill. CPNI does not include a customer's name, address, or telephone number.

(b) CenturyLink is required by law to treat CPNI confidentially. Member agrees that CenturyLink may share CPNI within its business operations (e.g., wireless, local, long distance, and broadband services divisions), and with businesses acting on CenturyLink's behalf, to determine if Member could benefit from the wide variety of CenturyLink products and services, and in its marketing and sales activities. Member may withdraw its authorization at any time by informing CenturyLink in writing. Member's decision regarding CenturyLink's use of CPNI will not affect the quality of service CenturyLink provides Member. However, in order to participate in CenturyLink's MiCTA program offering, Member must consent to the disclosure of CPNI to MiCTA, and by executing this Agreement, Member expressly provides its consent.

4.3 Private Line Service. If Member is amending an Agreement already containing Domestic Private Line, the following section is added to the Service Exhibit and replaces any conflicting language in the Service Exhibit:

RSS. Member understands that Service is an interstate telecommunications service, as defined by Federal Communications Commission regulations and represents that during the Service Term, more than 10% of its traffic will be interstate traffic.

4.4 HIPAA. If the Agreement has a HIPAA section, then that section is deleted and replaced with the following HIPAA section, otherwise the following section is added to the Agreement.

CenturyLink does not require or intend to access Member data in its performance hereunder, including but not limited to any confidential health related information of Member's clients, which may include group health plans, that constitutes Protected Health Information ("PHI"), as defined in 45 C.F. R. §160.103 under the Health Insurance Portability and Accountability Act of 1996 ("HIPAA Rules"). To the extent that any exposure to PHI is incidental to CenturyLink's provision of Service and not meant for the purpose of accessing, managing the PHI or creating or manipulating the PHI, such exposure is allowable under 45 CFR 164.502(a)(1)(iii).

4.5 The following is deleted from the "Service" Section:

Member represents that it is not a reseller of any telecommunication services provided under this Agreement as described in the Telecommunications Act of 1996, as amended, or applicable state law and acknowledges it is not entitled to any reseller discounts under any laws. Member's use of Services must comply with all applicable laws.

4.6 Addition to Local Access. The following will be added to the pricing table in Section 2 of the Local Access Pricing Attachment of the Agreement:

NPANXX	QPricer Loop Tracking ID	Address	Type of Local Access	Minimum Service Term (per Service)	Circuit Speed	Local Access Net Rate MRC	Install NRC
573875	161215730063	2145 E COUNTY DR COLUMBIA MO 65202	CLPA - ELA Native	36 month	Fast Ethernet- 20 Mbps	\$369.00	\$0.00
573682	161215730104	114 S ROLLINS ST CENTRALIA MO 65240	CLPA - ELA Native	36 month	Fast Ethernet- 5 Mbps	\$338.00	\$0.00
573882	161215730116	901 VIRGINIA AVE COLUMBIA MO 65201	CLPA - ELA Native	36 month	Fast Ethernet- 5 Mbps	\$203.00	\$0.00

*The Leased NRC Waiver described in Section 4 of the Local Access Pricing Attachment of the Agreement will apply to the circuits listed above.

4.7 The following section added to the Agreement:

No Resale; Security. Member represents that it is not a reseller of any telecommunication services provided under this Agreement as described in the Telecommunications Act of 1996, as amended, or applicable state law and acknowledges it is not entitled to any

127-2017

AMENDMENT TO
CENTURYLINK® LOYAL ADVANTAGE®
MICTA MEMBER PARTICIPATION CONTRACT

reseller discounts under any laws. CenturyLink has adopted and implemented, and will maintain, a corporate information security program designed to protect Member information, materials and data accessed and possessed by CenturyLink from loss, misuse and unauthorized access or disclosure. Such program includes formal information security policies and procedures. The CenturyLink information security program is subject to reasonable changes by CenturyLink from time to time. CenturyLink's standard service offerings do not include managed security services such as encryption, intrusion detection, monitoring or managed firewall. Member is responsible for selecting and using the level of security protection needed for all Member data stored or transmitted via the Service and using reasonable information security practices, including those relating to the encryption of data. CenturyLink will not be deemed to have accessed, received, or be in the possession of Member Confidential Information solely by virtue of the fact that Member transmits, receives, accesses or stores such information through its use of CenturyLink's Services. CENTURYLINK MAKES NO WARRANTIES OR REPRESENTATIONS THAT ANY SERVICE WILL BE FREE FROM LOSS OR LIABILITY ARISING OUT OF HACKING OR SIMILAR MALICIOUS ACTIVITY, OR ANY ACT OR OMISSION OF THE MEMBER.

5. Miscellaneous.

5.1 On April 1, 2014, CenturyLink completed an internal reorganization resulting in the merger of multiple CenturyLink owned companies into Qwest Communications Company, LLC. Simultaneously with the merger, Qwest Communications Company, LLC d/b/a CenturyLink QCC changed its name to CenturyLink Communications, LLC. The term "CenturyLink QCC" refers to the former "d/b/a CenturyLink QCC" company and not to any other CenturyLink owned companies now a part of CenturyLink Communications, LLC. References in the Agreement to "Qwest Communications Corporation," "Qwest Communications Company, LLC," or "QCC" are replaced with "CenturyLink Communications, LLC."

5.2 All references to the Master Agreement in the Agreement will refer to the Master Agreement available on the MiCTA Web site for Members located at www.mictatech.org. This Amendment will be effective as of the date it is executed by CenturyLink after the Member's signature (the "Amendment Effective Date") and will become part of the Agreement. All other terms and conditions in the Agreement shall remain in full force and effect and be binding upon the parties. This Amendment and the Agreement set forth the entire understanding between the parties as to the subject matter herein, and if there are any inconsistencies between the two documents, the terms of this Amendment will control. Using CenturyLink's electronic signature process for the Amendment is acceptable.

The undersigned parties have read and agree to the terms and conditions set forth in this Amendment.

MEMBER: Boone County

CENTURYLINK COMMUNICATIONS, LLC

[Signature]
Authorized Signature
ARON CISH
Name Typed or Printed
IT DIRECTOR
Title
4/24/2017
Date

DocuSigned by:
Jacob Darfler
C9E6AAC7E47E466...
Authorized Signature
Name Typed or Printed
Manager - Offer Management
Title
1/25/2017
Date

MiCTA Member No: *MFG-65201-02*

Boone County, Missouri
By: *[Signature]*
Boone County Commission
[Signature]
Daniel K. Atwell, Presiding Commissioner

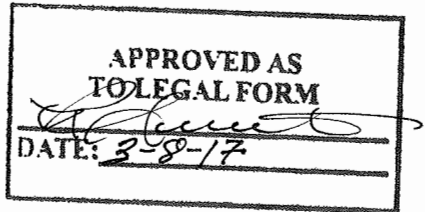

CERTIFICATION:
I certify that this contract is within the purpose of the appropriation to which it is to be charged and there is an unencumbered balance of such appropriation sufficient to pay the costs arising from this contract.
[Signature]
Auditor
3-8-17
Date

**AMENDMENT TO
CENTURYLINK® LOYAL ADVANTAGE®
MICTA MEMBER PARTICIPATION CONTRACT
CENTURYLINK IQ® DATA BUNDLE OFFER ATTACHMENT**

This CenturyLink IQ® Data Bundle offer attachment ("Attachment") is subject in all respects to the domestic CenturyLink IQ® Networking Service Exhibit, the Local Access Service Exhibit, the Rental CPE Service Exhibit, and the CenturyLink® Loyal Advantage® MICTA Member Participation Agreement ("Agreement") between Member and CenturyLink QCC, all of which must be executed between the parties for the offer in this Attachment to apply. All capitalized terms that are used but not defined in this Attachment are defined in the Agreement or Service Exhibit.

Scope. Member may purchase a Data Bundle Standard or Data Bundle Pro solution (each a "Data Bundle") under this Attachment. "Data Bundle Standard" is a combination of a CenturyLink IQ Networking Internet or Private Port, Local Access Service, and eligible pre-configured Rental CPE with 8x5 or 24x7 maintenance. Data Bundle Standard includes 10 Rental CPE configuration changes per year. "Data Bundle Pro" includes all Service elements and features of the Data Bundle Standard plus VPN Tunnel configuration, complex routing protocol configuration, NAT, PAT and DMZ configuration, and Ethernet switch options on the Ethernet-based bundles. VoIP configuration options are available with both Data Bundle Standard and Data Bundle Pro.

Eligibility and Restrictions. Member must order all the applicable Service elements in the Data Bundle at the same time under an Agreement with either a 24 or 36 month Term.

Data Bundle Ports and Local Access. The following CenturyLink IQ Networking Port bandwidths are available in a Data Bundle: DS1 through 8xDS1 and DS3 for the Data Bundle Standard and Ethernet 5 Mbps and 10 Mbps through 100 Mbps in 10 Mbps increments for the Data Bundle Pro (each a "Data Bundle Port"). Ethernet Data Bundle Ports are only available with Data Bundle Pro and must use ELA. If Member uses CPA or Cross Connect Access, Member must ensure that Local Access is compatible with CenturyLink's existing networking infrastructure and equipment, including the Rental CPE. CenturyLink will provide End-to-End Performance Reporting for Private Port or Enhanced Port Data Bundles. The Internet Port or Private Port Data Bundle Port MRC will be used to calculate Contributory Charges.

Rental CPE. The following table shows the eligible Rental CPE that may be used with each Port speed and Data Bundle.

Eligible Rental CPE available with all Data Bundle Port Types (Internet and Private)							
Bundle Types	DS1	2xDS1	3xDS1 4xDS1	5xDS1 6xDS1 7xDS1 8xDS1	With ELA: 5 Mbps and 10 – 100 Mbps*	DS3	
Data Bundle Standard	ADTRAN 3430	ADTRAN 3430	ADTRAN 908e w/ SBC [‡]	ADTRAN 4430	N/A	ADTRAN NV5305	
Data Bundle Pro	ADTRAN 908e w/ SBC [‡]	ADTRAN 908e w/ SBC [‡]	ADTRAN 908e w/ SBC [‡]	ADTRAN 4430	ADTRAN 908e w/ SBC [‡] or 1335P ^{**}	ADTRAN NV5305	
Data Bundle Standard	Cisco 1941	Cisco 1941	Cisco 1941	Cisco 2921-SEC	N/A	Cisco 2951	
Data Bundle Pro	Cisco 2921-VSEC	Cisco 2921-VSEC	Cisco 2921-VSEC	Cisco 2921-VSEC	Cisco 2921- VSEC	Cisco 2951	

*Bandwidths increase in 10 Mbps increments.

**The 1335P only supports Ethernet speeds up to 10 Mbps.

‡Session Border Controller

The Rental CPE must be configured and installed for use with a Data Bundle Port. CenturyLink may use repackaged Rental CPE or substitute the Rental CPE with other CPE. Rental CPE maintenance is provided under the applicable Detailed Description. 8x5 Next Business Day ("NBD") maintenance uses Pro-MET® Remote Standard Service and 24x7 on-site maintenance uses Pro-MET® On-Site Premium Service. Member may request password access for Rental CPE. If CenturyLink grants password access to Member: (a) Member waives any claim against CenturyLink or the manufacturer for maintenance, configuration support, repair, loss, or damage to the Rental CPE if a problem is caused by Member's use of the password, (b) Member is not entitled to any SLA credits, (c) CenturyLink is not obligated to provide any CPE configuration assistance and (d) any CenturyLink provided CPE configuration assistance will be at its then-current time and material rates.

2.3 Upgrade. During a Service Term, Customer may upgrade a Data Bundle with a Bandwidth Upgrade, Pro Upgrade, Maintenance Upgrade, or Port Upgrade (collectively an "Upgrade"). All Upgrades are subject to the Upgrade NRC. Customer may need to amend the Agreement to include a revised Term with an Upgrade. Bandwidth and Pro Upgrades must (a) keep the same CPE Rental brand, and (b) begin a new Service Term that is the same or longer than the existing Service Term except that Customer is not required to begin a new Service Term if both the Local Access circuit and the Rental CPE device do not change as part of the upgrade. CenturyLink may replace Customer's existing Rental CPE to support the higher bandwidth or a different bundle and Customer must return the existing Rental CPE to CenturyLink within 15 calendar days after the new Rental CPE is installed.

**AMENDMENT TO
CENTURYLINK® LOYAL ADVANTAGE®
MiCTA MEMBER PARTICIPATION CONTRACT
CENTURYLINK IQ® DATA BUNDLE OFFER ATTACHMENT**

- a. **Bandwidth Upgrade.** Customer may upgrade to a higher bandwidth or to a Managed Data Bundle, which is purchased separately, (each a "Bandwidth Upgrade") if the Data Bundle has been installed at least three months; provided, however, Customer may not upgrade an ELA speed to NxDS1 or DS3.
- b. **Pro Upgrade.** Customer may upgrade from a Data Bundle Standard to a Data Bundle Pro at the same bandwidth level ("Pro Upgrade") at any time during the Service Term.
- c. **Maintenance and Port Upgrade.** Customer may upgrade a Data Bundle with 8x5 NBD maintenance to 24x7 on-site maintenance ("Maintenance Upgrade") or from an Internet Port to a Private Port ("Port Upgrade") without restarting a new Service Term if Customer: (i) has a location and Rental CPE that qualifies, (ii) keeps the same bundle type and bandwidth and (iii) pays the Upgrade NRC.

- 1. **Moves.** Member may move a Data Bundle to a different Service Address within the same wire center ("Move"). Such Move will not restart the Service Term. Member must submit notice to CenturyLink at least 30 days before the requested Move date. Local Access ancillary charges may apply.

Relocation. Member may relocate a Data Bundle to a domestic Service Address outside of the wire center ("Relocation") if Member: (a) is relocating a Data Bundle that was installed at the old Service Address for at least 12 months, (b) submits the order for the new Service Address and the disconnect order for old Service Address at the same time, (c) submits a new order for a Bandwidth Upgrade, a Pro Upgrade or the same Data Bundle, (d) pays the Upgrade NRC and (e) follows the standard Upgrade process, if applicable. The Service Term will restart for a Relocation and must be the same or longer than the existing Service Term. If Member had 24x7 on-site maintenance at the old Service Address and 24x7 on-site maintenance is not available at the new Service Address as a part of a Relocation, Member may order a 36 month Data Bundle with standard 8x5 NBD maintenance. Member may be required to use the original Rental CPE at Member's new Service Address if CenturyLink determines that new or different Rental CPE is not necessary. If Member requires on-site assistance from CenturyLink to install the Rental CPE at the new Service Address, an additional dispatch fee will apply.

Rates and Charges. The rates and charges for the Services are as set forth in the MiCTA Master Agreement and CenturyLink's MiCTA Rate Schedule available on the MiCTA Web site at <http://www.mictatech.org>. If there is a conflict, the rates and charges set forth in the MiCTA Master Agreement shall control. Member will be obligated to pay all applicable MRCs and NRCs. Charges will commence within five days of CenturyLink's notification to Member that the Service is provisioned and ready for use ("Start of Service Date"). Any Service component charge not shown under the MiCTA Master Agreement will be provided to Member at CenturyLink's then current rates.

Data Bundle Pricing. The Data Bundle Port MRC includes the MRCs for the Data Bundle Port and Rental CPE. CenturyLink will waive End-to-End Performance Reporting MRCs. The Data Bundle pricing is exclusive of, and may not be combined any current offers, promotions, or discounts and will only be applied in lieu of any such discounts except the offer in this Attachment may be combined with certain CenturyLink Long Distance and Toll Free offers and the CenturyLink IQ Networking Transition Offer. After the Service Term for a Data Bundle expires, CenturyLink may modify pricing for the Data Bundle. Upgrades and additional Data Bundle orders after an initial order may be subject to then-current Data Bundle pricing.

Local Access Pricing. Local Access rates are set forth in the Local Access Service Exhibit.

Upgrade NRC. Member must pay the NRC in the table in this section for any Upgrade.

Description	Promo Code	NRC
Upgrade NRC	iQ BundleUPGR	\$275

Term; Cancellation.

Term. The term of an individual Data Bundle begins on the date CenturyLink notifies Member that a Data Bundle is provisioned and ready for use ("Start of Service Date") and will continue for the number of months as specified in Member's order for a Data Bundle ("Service Term"). If the CenturyLink IQ Networking Transition Offer and this Data Bundle offer both apply to a Port, the Eligible Service Minimum Term set forth in the Transition Offer will be the "Service Term" if it is greater than the Data Bundle Service Term. Upon expiration of a Service Term, the Data Bundle will remain in effect on a month-to month basis until canceled by either party with 60 days' prior notice.

Cancellation. Upon cancellation of a Data Bundle, Member will remain liable for charges accrued but unpaid as of the cancellation date. If a Data Bundle is canceled by Member other than for Cause, or by CenturyLink for Cause, before the conclusion of its Service Term, Member will pay: (a) a Data Bundle Port Cancellation Charge equal to: (i) 100% of the Data Bundle Port's MRC multiplied by the number of months remaining in the first 12 months of the Service Term, if any; plus (ii) 75% of the Data Bundle Ports MRCs multiplied by the number of months remaining to complete 24 months of the Service Term, if any; plus, if applicable, plus (iii) 50% of the Data Bundle Port's MRC multiplied by the number of months remaining to complete the remainder of the Service Term and (b) the Local Access Cancellation Charges set forth in the Local Access Service Exhibit.

**AMENDMENT TO
CENTURYLINK® LOYAL ADVANTAGE®
MICTA MEMBER PARTICIPATION CONTRACT
CENTURYLINK IQ® DATA BUNDLE OFFER ATTACHMENT**

Waiver of Cancellation Charges.

Upgrade. When Member Upgrades at the same Service Address, CenturyLink will waive (i) the Data Bundle Port Cancellation Charge, (ii) Local Access Cancellation Charge for ELA Data Bundles installed for at least 12 months, and (iii) Local Access Cancellation Charges for all other Data Bundles.

Moves. When Member's bundle type and bandwidth remain the same in a Move, CenturyLink will waive both the Data Bundle Port Cancellation Charge and Local Access Cancellation Charge.

Relocation. When Member has a Relocation, CenturyLink will waive (i) the Data Bundle Port Cancellation Charge and (ii) the Local Access Cancellation Charges for DS1 through 8xDS1 Data Bundles installed for at least 12 months. CenturyLink will not waive Local Access Cancellation Charges for Relocations of DS3 or Ethernet Data Bundles.

Rental CPE Purchase. Upon completion of a Service Term, Member may purchase Rental CPE at its fair market value. If Member intends to purchase Rental CPE, Member must notify CenturyLink of such intention at least 60 days before the end of the Service Term. Member will purchase Rental CPE on an "as-is" basis, with no representations or warranties of any kind, including no warranties of merchantability or fitness for a particular purpose. Title and responsibility of the applicable Rental CPE will immediately transfer to Member upon CenturyLink's receipt of payment. Once Member assumes title of Rental CPE, CenturyLink will no longer provide maintenance support or any configuration changes. Member will be responsible for purchasing or providing any separate maintenance for all purchased Rental CPE. Member is also responsible for proper disposal of all purchased Rental CPE, and hereby releases CenturyLink from all and any liability relating in any way to the purchased Rental CPE.

Add-On Connection. Member may add optional, CenturyLink-approved CPE cards as shown below ("Add-On Connection Cards") to certain Rental CPE if the following conditions are met: (a) the Rental CPE is associated with Data Bundle Pro, (b) there is an available slot in the Rental CPE, (c) Member purchases the Add-On Connection Card through CenturyLink and (d) the Add-On Connection Card is from the same manufacturer as the Rental CPE. Add-On Connection Cards are not covered under Rental CPE maintenance SLAs. CenturyLink will drop-ship Add-On Connection Cards to Member. Member may purchase on-site installation through CenturyLink or Member may install the Add-On Connection Cards. If Member installs any Add-On Connection Cards, Member must follow CenturyLink provided directions and Member waives any claim against CenturyLink or the Add-On Connection Card's manufacturer for maintenance, repair, loss, or damage to the Rental CPE. CenturyLink will support additional configurations for Add-On Connection Cards as part of the 10 configuration changes per year associated with the Rental CPE. Member must remove the Add-On Connection Card from the original Rental CPE device before shipping the Rental CPE back to CenturyLink or CenturyLink associated vendor. CenturyLink is not responsible for the loss of any Add-On Connection Cards. The Add-On Connection Cards and CenturyLink on-site installation are provided under a separate CenturyLink Service Exhibit with separate charges.

CenturyLink IQ Data Bundle Pro Rental CPE Routers that Support Add-On Connection Cards	
Router	CenturyLink IQ Data Bundle Bandwidth
Cisco 2921-VSEC	DS1
Cisco 2921-VSEC	2xDS1
Cisco 2921-VSEC	3xDS1 and 4xDS1
Adtran 4430 and Cisco2921-VSEC	5xDS1 through 8xDS1
Adttran1335POE	Up to 10 Mbps
Adtran 5305 and Cisco 2951	DS3
Cisco 2921-VSEC	5 Mbps, and 10 Mbps through 100 Mbps ELA in 10 Mbps increments

CenturyLink-approved Add-On Connection Cards	
Cisco	ADTRAN
HWIC-1DSU-T1	DS3 Wide Mod
VWIC3-2MFT-T1/E1	
NM-1 T3/E3	
EHWIC-4G-LTE-V	
GLC-SX-MMD	
GLC-LH-SMD	
EHWIC-1GE-SFP-CU	
HWIC-2FE	
EHWIC-4ESG	

Replacement Program. CenturyLink will replace a defective Add-On Connection Card within 15 business days after CenturyLink and Member mutually determine that the Add-On Connection Card should be replaced. The replacement program will no longer apply if Member purchases the Rental CPE device. The NRC for the replacement program is in the table in this section.

**AMENDMENT TO
CENTURYLINK[®] LOYAL ADVANTAGE[®]
MICTA MEMBER PARTICIPATION CONTRACT
CENTURYLINK IQ[®] DATA BUNDLE OFFER ATTACHMENT**

Description	NRC
Add-On Connection Card Replacement Program	\$50 per Add-On Connection Card

Miscellaneous. All other terms not specifically set forth in this Attachment, including without limitation, any other rate elements, are as stated in the Agreement and Service Exhibits and will remain in effect. The Data Bundle Pricing will become effective as soon as practicable, but in no event later than the second full billing cycle following the Agreement or Amendment Effective Date. If there is a conflict between any of the following documents, the order of control is: this Attachment, the Service Exhibits, and the Agreement, This Attachment, the CenturyLink IQ Networking Service Exhibit, the Local Access Service Exhibit, the Rental CPE Service Exhibit, and the Agreement set forth the entire understanding between the parties as to the subject matter herein and supersede any prior written or verbal statements, representations, and agreements concerning the subject matter hereof.



Boone County 911

Proposal for MPLS

Quote Expiration Date: 3/6/2017

Customer Copy Quote: 17-000092

Customer Contract ID: 138AN-TISA-2013-041

Customer Contact Information:

Boone County MO E911

Billing Address: 801 E Walnut Street, Rm 236, Columbia MO 65201-4890

Customer Contact: Pat Schreiner/573-886-7207/pschreiner@boonecountymmo.org

CenturyLink Contact Information:

Sales Person: Lynn Zinsser/lynn.zinsser@centurylink.com/314-917-8282

Teaming Sales Person: Scott Wise/scott.wise.centurylink.com

Engineer: Curt Kempf/curt.kempf@centurylink.com/573-886-3394

Service Description: The following term options reflect the total Monthly Recurring (MRR) and Non-Recurring (NRR) for all sites included in the quote. See subsequent pages for the individual charges per site.

Type of Service: MPLS

Term Agreement: 36 Months

Total number of sites included in this quote:

Site	Listing Name	MRR	NRR
A	Centralia PD - 114 S Rollins St - 5Mb MPLS #4	\$660.00	\$0.00
B	UM Police - 901 Virginia Avenue - 5Mb MPLS #5	\$525.00	\$0.00
C	Boone Co 911 - 2145 E County Dr - 20Mb MPLS #2	\$875.00	\$0.00
	TOTAL	\$2,060.00	\$0.00

*****Centurylink Proprietary and Confidential*****



Boone County 911

Proposal for MPLS

Quote Expiration Date: 3/6/2017

Customer Copy Quote: 17-000092

Customer Service Location: PON #:

Primary Location Name: Centralia PD, 114 S Rollins St, 5Mb MPLS #4

Address: 114 S Rollins Street, Centralia MO 65240, NPA-NXX: 573-996

On-Site Contact Name: Beth Boos Work TN: 573-886-7209

Telco Central Office Information:

Telco A: CenturyTel of Missouri, LLC(Central) DBA CenturyLink

Service Central Office: CENLMOXA1AW

Serving Central Office Address: 114 S Rollins Street, Centralia, MO 65240

Service Description:

Type of Service: MPLS, 36 Month Term

Site	QTY	Price Plan	Feature Code	Item	MRR	NRR
A	1	PPECL3Z4B	E171	5Mb MPLS	\$660.00	\$0.00
				TOTAL	\$660.00	\$0.00

Additional Terms & Conditions: At [Http://about.centurylink.com/legal/rates_conditions.html](http://about.centurylink.com/legal/rates_conditions.html), the following information will direct you to the applicable terms and conditions for the Services. Entity: CenturyTel of Missouri, LLC(Central) DBA CenturyLink. The prices quotes only apply to the sites included in the Quote and will not apply if customer adds, changes or moves site locations. Rates, charges and discounts for Service elements not identified appear in the applicable terms and conditions above. Prices do not include taxes or applicable surcharges that CenturyLink may bill Customer. Unless the Quote is incorporated into the signed agreement, it is non-binding. Except for charges described in the quote, the applicable CenturyLink terms and conditions identified above, will control over any inconsistencies or conflicts between the Quote and the terms and conditions.

*****Centurylink Proprietary and Confidential*****

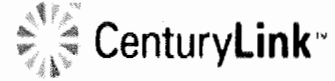

Boone County 911

Proposal for MPLS

Quote Expiration Date: 3/6/2017

Customer Copy Quote: 17-000092

Customer Service Location: PON #:

Primary Location Name: UM Police, 901 Virginia Avenue, 5Mb MPLS #5

Address: 901 Virginia Avenue, Columbia MO 65201, NPA-NXX: 573-886

On-Site Contact Name: Beth Boos Work TN: 573-886-7209

Telco Central Office Information:

Telco A: CenturyTel of Missouri, LLC(Central) DBA CenturyLink

Service Central Office: CLMAMOXA

Serving Central Office Address: 625 Cherry Street, Columbia MO 65201

Service Description:

Type of Service: MPLS, 36 Month Term

Site	QTY	Price Plan	Feature Code	Item	MRR	NRR
A	1	PPECL3Z4B	E171	5Mb MPLS	\$525.00	\$0.00
				TOTAL	\$525.00	\$0.00

Additional Terms & Conditions: At [Http://about.centurylink.com/legal/rates_conditions.html](http://about.centurylink.com/legal/rates_conditions.html), the following information will direct you to the applicable terms and conditions for the Services. Entity: CenturyTel of Missouri, LLC(Central) DBA CenturyLink. The prices quotes only apply to the sites included in the Quote and will not apply if customer adds, changes or moves site locations. Rates, charges and discounts for Service elements not identified appear in the applicable terms and conditions above. Prices do not include taxes or applicable surcharges that CenturyLink may bill Customer. Unless the Quote is incorporated into the signed agreement, it is non-binding. Except for charges described in the quote, the applicable CenturyLink terms and conditions identified above, will control over any inconsistencies or conflicts between the Quote and the terms and conditions.

*****Centurylink Proprietary and Confidential*****



Boone County 911

Proposal for MPLS

Quote Expiration Date: 3/6/2017

Customer Copy Quote: 17-000092

Customer Service Location: PON #:

Primary Location Name: 2145 E County Dr, 20Mb MPLS #2

Address: 2145 E County Drive, Columbia MO 65202, NPA-NXX: 573-886

On-Site Contact Name: Beth Boos Work TN: 573-886-7209

Telco Central Office Information:

Telco A: CenturyTel of Missouri, LLC(Central) DBA CenturyLink

Service Central Office: CLMAMOXA

Serving Central Office Address: 625 Cherry Street, MO 65201

Service Description:

Type of Service: MPLS, 36 Mont h Term

Site	QTY	Price Plan	Feature Code	Item	MRR	NRR
A	1	PPECL3Z1B	E173	20Mb MPLS	\$875.00	\$0.00
				TOTAL	\$875.00	\$0.00

Additional Terms & Conditions: At [Http://about.centurylink.com/legal/rates_conditions.html](http://about.centurylink.com/legal/rates_conditions.html), the following information will direct you to the applicable terms and conditions for the Services. Entity: CenturyTel of Missouri, LLC(Central) DBA CenturyLink. The prices quotes only apply to the sites included in the Quote and will not apply if customer adds, changes or moves site locations. Rates, charges and discounts for Service elements not identified appear in the applicable terms and conditions above. Prices do not include taxes or applicable surcharges that CenturyLink may bill Customer. Unless the Quote is incorporated into the signed agreement, it is non-binding. Except for charges described in the quote, the applicable CenturyLink terms and conditions identified above, will control over any inconsistencies or conflicts between the Quote and the terms and conditions.

*****Centurylink Proprietary and Confidential*****

Customer Responsibilities – Ethernet Services described in this Price Quote

If the following responsibilities are not completed before installation of the Ethernet services described in this Price Quote (“Ethernet Services”), CenturyLink reserves the right, at its sole discretion, to reschedule installation, charge Customer for additional work and any necessary materials or Products on a Time and Material basis, or terminate the Agreement (to which this Price Quote is incorporated) with respect to Ethernet Services and any associated services utilizing Ethernet Services.

1. Customer must provide adequate conduit from the right-of-way into the building and confirm access facilities to the building are available for fiber provisioning. It is also Customer’s responsibility to locate private utilities on the premises if construction is required. Conduit specifications are as follows: One 2-inch Schedule 40 PVC conduit from 2 feet below grade at the building exterior to a pull box on the building exterior. Pull box must have a minimum dimension of 12-inch x 12-inch x 6-inch deep. Place one 2-inch conduit sleeve through wall from pull box to inside of the equipment room. Conduit must be equipped with 200 lb rated pull tension or greater. Equip conduit with no more than 2 quarter bends (a total of 180 degrees) between cable pulling points. Seal the conduit after installation to protect from damage such as water.

Conduit is not required when Ethernet Service is provisioned over copper or circuit bonding technology, 50 Mbps or less. Ethernet Services delivered via copper/circuit bonding technology will terminate at the CenturyLink demarcation point on a Customer-provided wall-mounted 66 block and cross-connected to a copper loop bonding unit.

2. Customer must provide one 20 x 44 x ¾ inch plywood backboard in an equipment demarcation room with clearance of 36 inches in front of backboard. If the fiber demarcation point is within 25 feet of the equipment rack, a wall board will not be required. All hardware and terminations will be installed in the Customer-provided rack.

If Customer is in a multi-tenant building and the shared building terminal at Customer’s location does not have adequate space for CenturyLink fiber termination, Customer or building owner must provide a 24” x 24” x 9” cabinet with ¾” plywood. This cabinet must be associated next to the original building terminal to support association of shared demarcation facilities.

3. Customer must ensure the demarcation point is in an accessible and environmentally controlled location. All CenturyLink Ethernet Services-enabling Equipment requires a clean, dust-free environment that is environmentally controlled to temperatures of 55-80 degrees Fahrenheit and humidity of 70% or less. If Customer is in a multi-tenant building, Customer must ensure that the CenturyLink demarcation point, is accessible to CenturyLink technicians. Customer may need to coordinate access with the building manager to ensure that access is available on the day of installation. Customer must ensure that this location remains dry and free of dampness, and the room temperature remains within the tolerance of sensitive electronic hardware.
4. Customer must ensure 4 consecutive rack units of space in a 19” data rack are available for Ethernet Services. Customer must provide space in a 19” wide data rack for the required hardware. The rack must be either wall or floor mounted. CenturyLink will not install the hardware on a shelf or the floor.
5. Customer must provide a dedicated power outlet and common ground. CenturyLink termination electronics are powered by Customer-provided 120 VAC (20 Amp) circuit. CenturyLink requires the outlet to be a duplex, dedicated and grounded electrical outlet within 6 feet of the equipment location. Common ground must be 25 ohm or less. If Customer does not have an uninterruptible power supply (UPS) on the AC, Ethernet Services will be lost in the event of an AC power failure. If UPS is required, Customer will provide. CenturyLink will provide for an additional charge upon request.
6. Customer must complete inside wiring before the arrival of the CenturyLink installation technicians. Customer must extend the wiring from the demarcation point to the location where the Ethernet Services will be used.

CenturyLink only will extend the demarcation point on a Time and Material basis for an additional charge. Customer must contact its CenturyLink Account Executive to schedule the work. CenturyLink uses the following guidelines when extending the demarcation point: (1) If services are delivered via copper (50 Mbps or less), the

demarcation may be extended a maximum of 300 feet 24 gauge copper, or (2) If services are delivered via fiber, CenturyLink technicians will terminate fiber into a Customer-provided rack a maximum of 25 feet from demarcation.

- 7. Customer must confirm Ethernet Service hand-off requirements. CenturyLink will provide a standard RJ-45 copper Ethernet connection for 10/100 service and a single mode fiber connection on a 1 Gigabit circuit as the demarcation point for the Ethernet Services. If a different customer hand-off is required, such as a multimode fiber connection, Customer must state the requirement on the site survey per site network page.
- 8. Customer must confirm that its Local Area Network ("LAN") has an appropriate Ethernet Service port available to provide the desired network functionality and is within the distance required by Ethernet Service specifications. Customer will program the Ethernet Service port for appropriate speed and full duplex setting. (auto-negotiate is not available). Customer will provide CAT5 cable(s) to connect its LAN to the CenturyLink Ethernet Service-enabling equipment. Customer will provide an appropriate Ethernet Service-enabling patch cable for connecting CenturyLink demarcation and Customer-provided Equipment.
- 9. Ethernet Services are a Layer 2 network service only. All customer premises LAN Layer 3 (e.g. IP) addressing is Customer's responsibility. CenturyLink will provide pricing for additional equipment and labor to enable Layer 3 functionality, if required. In most cases this will be a router which will provide the Layer 3 routing of subnets and VLAN on Customer's network. If Customer only requires Layer 2 bridging (a flat network) across the Ethernet Services, then a standard Ethernet Service switch port is all that is required.
- 10. The CenturyLink installer will not connect Ethernet Services to Customer's LAN. CenturyLink installers will install the hardware and identify a port for connection. CenturyLink highly recommends the use of a qualified networking vendor to assist with LAN configuration. A CenturyLink Account Executive can provide pricing for CenturyLink network configuration for Ethernet Services.

Ethernet Services will be installed at your site only upon completion of all of these steps. If Customer is unable to complete all of these requirements before the installation date, Customer will notify CenturyLink as soon as it becomes aware of its inability.

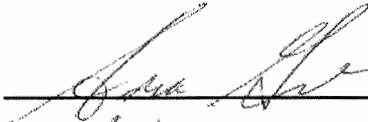
Customer Signature: 

Printed Name: Aaron Bosh

Date: 1/29/17

CenturyLink Signature: 

Printed Name: Jacob Darfler

Date: 1/26/2017

128 -2017

CERTIFIED COPY OF ORDER

STATE OF MISSOURI }
County of Boone } ea.

March Session of the January Adjourned

Term. 20 17

In the County Commission of said county, on the 16th day of March 20 17

the following, among other proceedings, were had, viz:

Now on this day the County Commission of the County of Boone does hereby approve the attached agreement between Boone County and A Civil Group, LLC for professional services related to Legal Descriptions Research and Drafting for 2017 Delinquent Tax Sale.

The terms of the Agreement are stipulated in the attached Agreement. It is further ordered the Presiding Commissioner is hereby authorized to sign said Agreement for Professional Services with A Civil Group, LLC.

Done this 16th day of March, 2017.

ATTEST:

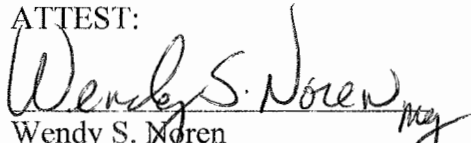

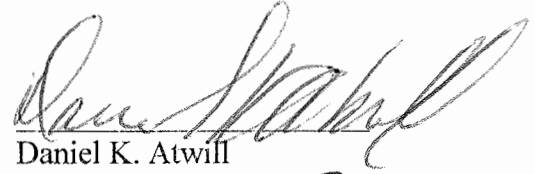
Wendy S. Noren
Clerk of the County Commission

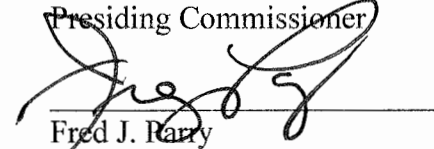

Daniel K. Atwill
Presiding Commissioner

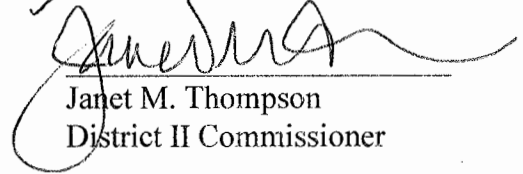

Fred J. Rary
District I Commissioner



Janet M. Thompson
District II Commissioner

128-2017

APPROVAL OF PROPOSAL FOR CONSULTANT SERVICES

Effective the 16th day of March 2017, Boone County, Missouri, a political subdivision of the State of Missouri through its County Commission (herein "Owner") hereby approves and authorizes professional services by the Consultant referred to below for the services specified herein.

Consultant Name: A Civil Group, LLC

Project/Work Description: Legal Descriptions research and drafting for 2017 Delinquent Tax Sale

Proposal Description: Services will be provided as requested by the County Collector at the attached rates, with research to be billed at the rate of \$95.00 per hour, with a total contract not to exceed \$4,000.00 without additional, written approval from the County.

Modifications to Proposal: Owner's representative shall be considered the Boone County Collector of Revenue. Consultant shall provide an itemized charge per legal description prepared, in addition to Consultant's monthly invoices for payment, to allow the addition of said direct cost to the relevant parcel as part of the costs of the delinquent tax sale.

This form agreement and any attachments to it shall be considered the approved proposal; signature by all parties below constitutes a contract for services in accordance with the above described proposal and any approved modifications to the proposal, both of which shall be in accordance with the terms and conditions of the General Consultant Services Agreement signed by the Consultant and Owner for the current calendar year on file with the Boone County Resource Management Department, which is hereby incorporated by reference. Performance of Consultant's services and compensation for services shall be in accordance with the approved proposal and any approved modifications to it and shall be subject to and consistent with the General Consultant Services Agreement for the current calendar year. In the event of any conflict in interpretation between the proposal approved herein and the General Consultant Services Agreement, or the inclusion of additional terms in the Consultant's proposal not found in the General Consultant Services Agreement, the terms and conditions of the General Consultant Services Agreement shall control unless the proposal approved herein specifically identifies a term or condition of the General Consultant Services Agreement that shall not be applicable or this Approval of Proposal indicates agreement with a specific term or terms of Consultant's proposal not found in the General Consultant Services Agreement.

A CIVIL GROUP, LLC

By Jay Gebhardt
Jay Gebhardt, Chief Operating Member
Dated: 3/16/17

BOONE COUNTY, MISSOURI

By Wendy S. Nowak
Presiding Commissioner
Dated: 3-16-17

APPROVED AS TO FORM:

[Signature]
County Attorney

ATTEST:

Wendy S. Nowak
County Clerk

APPROVED:

[Signature]
Collector of Revenue

Certification:

I certify that this contract is within the purpose of the appropriation to which it is to be charged and there is an unencumbered balance of such appropriations sufficient to pay the costs arising from this contract.

Jane E. Pitchford 3/17/17 1150-71116
Auditor by [Signature] Date

A CIVIL GROUP

**FEE SCHEDULE
2017**

ENGINEER I	\$ 135 / HOUR
ENGINEER II	\$ 130 / HOUR
ENGINEER III	\$ 125 / HOUR
ENGINEER IV	\$ 110 / HOUR
DESIGNER	\$115 / HOUR
SURVEYOR I	\$ 100 / HOUR
SURVEYOR II	\$ 85 / HOUR
SURVEYOR III	\$ 75 / HOUR
DESIGN TECHNICIAN I	\$ 95 / HOUR
DESIGN TECHNICIAN II	\$ 90 / HOUR
DESIGN TECHNICIAN III	\$ 80 / HOUR
1-MAN FIELD CREW	\$ 130 / HOUR
2-MAN FIELD CREW	\$ 150 / HOUR
CLERICAL	\$65 /HOUR
OUTSIDE COPIES	ACTUAL EXPENSE
OFFICE COPIES	
LARGE COPIES	\$3.00-\$5.00/EACH
BLACK AND WHITE COPIES	\$0.50/EACH
COLOR COPIES	\$1.00/EACH

CERTIFIED COPY OF ORDER

March Session of the January Adjourned

Term. 20 17

STATE OF MISSOURI }
County of Boone } ea.

In the County Commission of said county, on the 16th day of March 20 17

the following, among other proceedings, were had, viz:

Now on this day the County Commission of the County of Boone does hereby approve the request by the Prosecuting Attorney's Office to hire above the Flexible Hiring Maximum for the position of Assistant Prosecuting Attorney II at an annual salary of \$73,000.

Done this 16th day of March, 2017.

ATTEST:

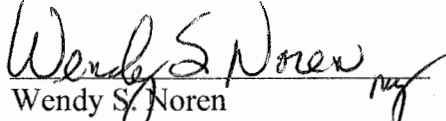

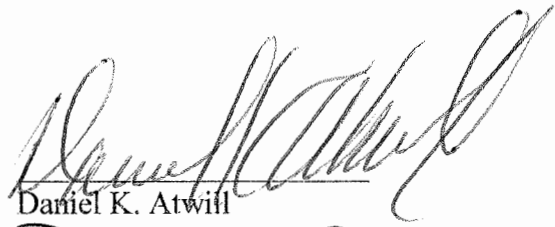
Wendy S. Noren
Clerk of the County Commission

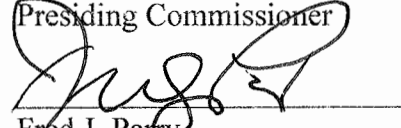

Daniel K. Atwill
Presiding Commissioner

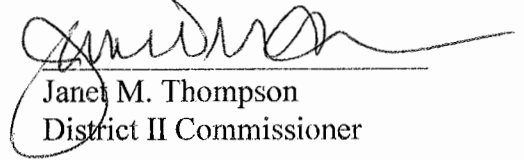

Fred J. Parcy
District I Commissioner



Janet M. Thompson
District II Commissioner

REQUEST TO HIRE ABOVE FLEXIBLE HIRING MAXIMUM

BOONE COUNTY

RECEIVED

MAR 13 2017

BOONE COUNTY AUDITOR

Description of form: To request approval to hire between 86% - 120% of the salary range mid-point

Procedure:

1. The Administrative Authority or designee completes the form and prepares a schedule that demonstrates that funding is available within the salary and wage appropriation (account #10100) and calculates the amount for a budget revision, if needed. The Administrative Authority submits the form, the schedule, and the budget revision (if needed) to the Auditor for certification of funds availability.
2. The Auditor certifies funds availability and approves budget revision (if applicable) and forwards to Human Resource Director.
3. The Human Resource Director reviews the information, makes recommendation, and schedules the request on the Commission agenda for approval.
4. The County Commission will review all requests for a starting salary above the mid-point and will either approve or deny the request. After approval/denial, the County Commission will return this form to the Administrative Authority.
5. The Administrative Authority will attach a copy of this approved form to the Personnel Action Form.

Name of prospective employee Former Assistant Prosecuting Attorney Department 1261 PA Administration

Position Title Assistant Prosecuting Attorney II Position No. 597

Proposed Starting Salary (complete one only) Annual: \$73,000.00 % of Mid-Point _____
 OR Hourly: _____ % of Mid-Point _____

No. of employees in this job classification within your Department? 11

Justification (Describe the prospective employee's education and/or work experience which supports this proposed compensation level)

This former assistant prosecuting attorney has been licensed to practice law since 2005 and was an assistant prosecuting attorney with our office from 2008 to 2016. Prior to coming to the Boone County Prosecuting Attorney's office he worked for the Missouri Attorney General's office in the criminal division.

If proposed salary exceeds what other employees in the same job classification are paid, explain how the prospective employee's background exceeds others working in the same job classification:

This former APA has a tremendous amount of criminal law experience. Over his career he handled hundreds of felonies and thousands of misdemeanors for our office. He is a very talented and proficient trial lawyer and has handled numerous complex cases. He is extremely intelligent, hard working, thoughtful and conscientious. In his previous employment with our office he worked well with victims, witnesses, police officers, other attorneys and judges.

What effect, if any, will this proposal have on salary relationships with other positions in your office and/or positions in other offices?

This salary is in line with other assistant prosecuting attorneys in our office with similar experience.

Additional comments:

There will be no overall budgetary impact because a long term employee is retiring from our office and this increase will be covered by that savings.

Administrative Authority's Signature: Samuel K. Knight Date: 2-13-17

Auditor's Certification: Funds are available within the existing departmental salary and wage appropriation (#10100).
 Funds are not available within the existing departmental salary and wage appropriation (#10100); budget revision required to provide funding is attached.

Auditor's Signature: Jane E. Ketchum by cg Date: 3/13/17

on-going increased annual cost including benefits equals \$11,975

Human Resource Director's Recommendations:
Approved by HR in salary study Phase II

Human Resource Director's Signature: [Signature] Date: 3/13/17

County Commission Approve Deny

Comment(s): _____

Presiding Commissioner's Signature: [Signature] Date: 3/16/17
 District I Commissioner's Signature: [Signature] Date: 3/16/17
 District II Commissioner's Signature: [Signature] Date: 3/16/17

CERTIFIED COPY OF ORDER

STATE OF MISSOURI }
 County of Boone } ea.

March Session of the January Adjourned

Term. 20 17

In the County Commission of said county, on the 16th day of March 20 17

the following, among other proceedings, were had, viz:

Now on this day the County Commission of the County of Boone does hereby authorize the Mid-Missouri Regional Planning Commission (MMRPC) to pursue an application for CDBG funds relating to the American Outdoor Brands improvement project and selects MMRPC to provide administrative services relating to said grant funds if the grant is ultimately awarded. If the CDBG funds are awarded, the County Commission will enter into a formal agreement with MMRPC for professional administration services relating to said grant. Pursuant to Boone County's Grant Policy, the Commission notes that the CDBG funds require a 15% local match and that said local match can be met with tax abatements and in-kind services.

Done this 16th day of March, 2017.

ATTEST:

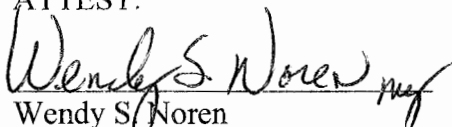
 Wendy S. Noren
 Clerk of the County Commission

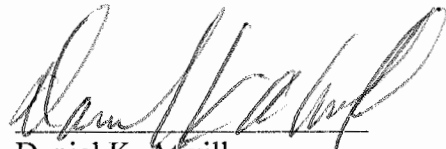
 Daniel K. Atwill
 Presiding Commissioner

 Fred J. Parry
 District I Commissioner

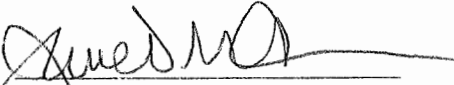
 Janet M. Thompson
 District II Commissioner



Title: Authorization. Mid-Missouri Regional Planning Commission.

Description: For planning services to include: preparation of the environmental review report, community development block grant application, and grant administration services for funding support for necessary public infrastructure improvements related to the American Outdoor Brands Corporation economic development project.

Fees for the environmental review and grant administration planning services are an eligible cost within the awarded grant funds. The MO-DED CDBG program dictates the maximum fee for such services to not exceed \$10,000 plus 3% of grant award.

Mid-MO RPC prepares grant applications at no cost to the local government membership.



Proposed Amendment to State Community Development Block Grant (CDBG) Procurement for Grant Administration Services

The Missouri Department of Economic Development, in order to streamline the procurement for CDBG grant administration services and still promote free and open competition, amended the administration procurement process as follows:

Cities and counties which are member organizations of a regional planning commission (RPC) or council of governments (COG) may contract directly with that RPC or COG if both of the following conditions are met:

- 1. The city or county, as the CDBG grantee, must be a dues-paying member in good standing of the RPC or COG, and must be able to provide documentation of its membership in good standing.*
- 2. The CDBG application was prepared either by the city/county itself, or by the RPC or COG. If another third-party entity assisted the city/county with the application preparation, grant administration must then be procured.*

City and county grantees are not required to use the RPC/COG, and may elect to procure for grant administration even if both of the above conditions are met. This is simply an option that city and county grantees may use.

CERTIFIED COPY OF ORDER

STATE OF MISSOURI }
County of Boone } ea.

March Session of the January Adjourned

Term. 20 17

In the County Commission of said county, on the 16th day of March 20 17

the following, among other proceedings, were had, viz:

Now on this day the County Commission of the County of Boone does hereby authorize the approval of Change Order #51 to Boone County Emergency Communications Center Bid Number 44-11DEC14 to modify the annunciator alarm located in Dispatch 129.

The terms of the Change Order are stipulated in the attached Change Order #51. It is further ordered that Commissioner Janet M. Thompson is hereby authorized to sign said Change Order.

Done this 16th day of March, 2017.

ATTEST:

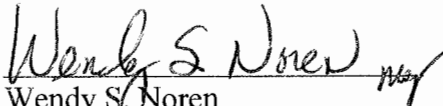
Wendy S. Noren
Clerk of the County Commission

Daniel K. Atwill
Presiding Commissioner

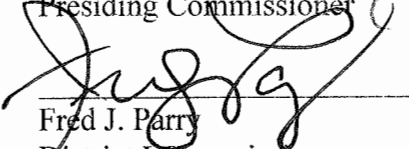
Fred J. Parry
District I Commissioner

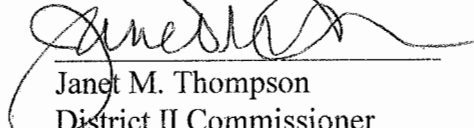
Janet M. Thompson
District II Commissioner

CHANGE ORDER

PROJECT:
Boone County Emergency Communications Center
Bid Number 44-11DEC14

CHANGE ORDER NUMBER: 51

OWNER:
Boone County Commission
Boone County Government Center
801 E. Walnut, Rm 333
Columbia, MO 65201-7732

DATE OF ISSUANCE: 3/10/2016
CONTRACT DATE: 1/27/2015

TO CONTRACTOR:
Little Dixie Construction, LLC
3316 Lemone Industrial Blvd.
Columbia, Missouri 65201

ADG PROJECT NUMBER: 916-13
PWA PROJECT NUMBER: 201340

ARCHITECT:
Architects Design Group
333 Knowles Ave.
Winter Park Florida 32789

PWArchitects, Inc.
15 S. Tenth Street
Columbia, MO 65201

Change Order Number 51:

The Contract is changed as follows:

1. Modify the annunciator alarm located in Dispatch 129 at the supervisors console to eliminate the audible signal as requested by the Owner per RFP #45 and Change Order Request #097.....
.....\$ 9,716.00

Total CO #51.....\$ 9,716.00

Not valid until signed by the Owner, Architect and Contractor.

The original Contract Sum was	\$ 9,933,707.00
Net change by previously authorized Change Orders	\$ 861,861.89
The Contract Sum prior to this Change Order was	\$ 10,795,568.89
The Contract Sum will be increased/decreased by this Change Order in the amount of	\$ 9,716.00
The new Contract Sum including this Change Order will be	\$ 10,805,284.89
The Original Contract Time +/- previous change orders for the project was	297 days
Contract Period for Construction is Increased/Decreased by	0 days
New Contract Period for New Building and Site	297 days
Contract Completion Date is	April 29, 2016

ARCHITECT
Architect's Agent
Erik Miller, AIA, CDT
Principal, PWA Architects, Inc.

BY



DATE 3.13.17

CONTRACTOR
Little Dixie Construction, LLC
John States
Owner

BY

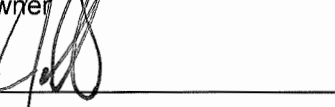

DATE 3-13-17

OWNER
Boone County, Missouri
Janet M. Thompson
District II Commissioner

BY



DATE 3/16/17

CERTIFICATION:

I certify that this contract is within the purpose of the appropriation to which it is to be charged and there is an unencumbered balance of such appropriation sufficient to pay the costs arising from this contract.

June Pitchford by HE 3-13-17

Auditor

Date

OWNER'S REPRESENTATIVE
Boone County Resource Management
Doug Coley
Director of Facilities

BY

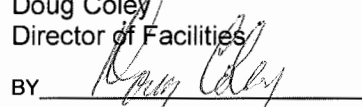

DATE

3/13/17



3316 LeMone Industrial Blvd. / Columbia, Missouri 65201 / office 573.449.7200 / fax 573.449.7300
littledixieconstruction.com

CHANGE ORDER REQUEST #097

PROJECT: Boone County Emergency
Communication Center
2145 E County Drive
Columbia, MO 65202

LDC# 15010

Request Submitted to: Janet Thompson
Boone County Commission
801 E. Walnut, Room 333
Columbia, MO 65201-7732

Phone: 573-886-4305

Description	Deductive	Additive	Unit Costs
5PW Architects Request For Proposal Number 45			
LDC Mobilization		\$ 1,500	
Teel Mechanical		\$ 6,381	
LDC Clean Up		\$ 1,200	
	\$ -	\$ 9,081	\$ -
7% General Conditions, Profit & Overhead		\$ 636	
Subtotals	\$ -	\$ 9,716	\$ -
TOTAL		\$9,716	

Attachments:

- PW Architects Request For Proposal #45 dated 2/7/2017
- Teel Mechanical Change Order titled RFP-45 dated February 23, 2017
- C&C Group proposal to Richard Teel titled RFP-45 dated February 22, 2017
- Meyer Electric Change Order Proposal #23934 to C&C Group dated 2/20/2017

Time Extension Request: 0 Work Days

SUBMITTED BY: Joseph W. Gruender
Joseph W. Gruender, Senior Project Manager

DATE: 2/23/2017

PROPOSAL REQUEST

PROJECT:
Boone County Emergency Communications Center
Bid Number 44-11DEC14

REQUEST FOR PROPOSAL NUMBER: 45

DATE OF ISSUANCE: 2/7/2017
CONTRACT DATE: 1/27/2015

OWNER:
Boone County Commission
Boone County Government Center
801 E. Walnut, Rm 333
Columbia, MO 65201-7732

ADG PROJECT NUMBER: 916-13
PWA PROJECT NUMBER: 201340

TO CONTRACTOR:
Little Dixie Construction, LLC
3316 Lemone Industrial Blvd.
Columbia, Missouri 65201

ARCHITECT:
Architects Design Group
333 Knowles Ave.
Winter Park Florida 32789

PWArchitects, Inc.
15 S. Tenth Street
Columbia, MO 65201

Please submit an itemized proposal for changes in the Contract Sum and Contract Time for proposed modifications to the Contract Documents described herein. Submit proposal within 10 business days, or notify the Architect in writing of the date on which you anticipate submitting your proposal.

THIS IS NOT A CHANGE ORDER, A CONSTRUCTION CHANGE DIRECTIVE OR A DIRECTION TO PROCEED WITH THE WORK DESCRIBED IN THE PROPOSED MODIFICATIONS. AN OFFICIAL CHANGE ORDER WILL FOLLOW ONLY AFTER THIS REQUEST HAS BEEN RESPONDED TO WITH AN OFFICIAL APPROVAL TO PROCEED BY THE OWNER.

Description:

1. The annunciator alarm located in Dispatch 129 at the supervisors console should be modified to eliminate the audible signal as follows:

Connect to the Modbus output on each of the two generator controllers and wire to the Building Automation System to provide all available points and develop graphics for those points. Alarms shall be communicated through the BAS and shall trigger the warning light over the door leading from Dispatch 129 to Corridor 130. The audible alarms on the annunciator panels shall be permanently silenced by the generator supplier.

Attachment/s: None

By: Erik Miller, AIA, CDT
PWArchitects, Inc. (PWA)

TEEL MECHANICAL SERVICE, INC.
Air Conditioning, Heating, Refrigeration, Ventilation

4388 County Road 203 • Fulton, Missouri 65251 • Phone (573) 642-9648 • Fax (573) 642-1313

February 23, 2017

Little Dixie Construction
3316 Lemone Ind. Blvd
Columbia, MO 65201

RFP-45

Requests integration of the generator panels via a Modbus protocol. C&C scope includes the addition of a Modbus driver to the existing system panel, wiring of a Modbus communication trunk to each of the Generator panels, programming, graphics, and field verification of functionality. Additionally, the generator panels will be reprogrammed to eliminate the audible alarm functionality. In an alarm condition, the generators will send the alarm notification to the BAS which will illuminate the existing BAS alarm light to notify the occupants of the condition. Cost to complete this work is listed below.

Material:		\$ 395.00
Engineering:	12 hrs @ \$73.81	\$ 885.72
Technician:	4 hrs @ \$73.81	\$ 295.24
Proj Man:	4 hrs @ \$72.00	\$ 288.00
Electrical:		<u>\$ 2759.69</u>
Subtotal:		\$ 4623.65
20% OH&P		<u>\$ 924.73</u>
Subtotal:		\$ 5548.38
Teel 15% OH&P		<u>\$ 832.26</u>
Total:		\$ 6380.64

Total: \$ 6380.64



February 22, 2017

Richard Teel
Teel Mechanical Service Inc
4388 County Road 203
Fulton MO 65251

Re: RFP-45

Richard,

We have received RFP-45 which requests integration of the generator panels via a Modbus protocol. Our scope includes the addition of a Modbus driver to the existing system panel, wiring of a Modbus communication trunk to each of the Generator panels, programming, graphics, and field verification of functionality. Additionally, the generator panels will be reprogrammed to eliminate the audible alarm functionality. In an alarm condition, the generators will send the alarm notification to the BAS which will illuminate the existing BAS alarm light to notify the occupants of the condition. Cost to complete this scope of work is \$5,548.38.

Material:		\$395.00
Engineering	12hrs @ \$73.81	885.72
Technician	4hrs @ \$73.81	295.24
Proj Man	4hrs @ \$72.00	288.00
Electrical		<u>2,759.69</u>
Subtotal		4,623.65
OH&P @ 20%		<u>924.73</u>
Total		\$5,548.38

If there are any questions regarding this proposal, please contact us at 573-632-4247.

Sincerely,

Brian Schepers
C&C Group



MEYER ELECTRIC INC.

3513 North Ten Mile Drive
Jefferson City, MO 65109

ph: (573) 893-2335 fax: (573) 893-3686
office@meyerelectric.net

C & C Group
2414 Hyde Park Rd. Ste.B
Jefferson City, MO 65109

Attention: Brian Schepers

CHANGE ORDER PROPOSAL

2/20/2017

Boone Co. Em.Call Cntr Temp Cn
BooneCo Em Cntr
Our Job #: 36204

Meyer Ref #: 23934

RFP #45 - The following is a breakdown of cost to have generator supplier reconnect alarm circuit and Meyer Electric Company to install field wiring, per RFP #45:

Material	Quantity	Cost
400' 1 pair low cap orange 24 ga remove-replace raised floor	1.00 LS	240.00
25 - med tie wraps	1.00 LS	5.00
cost from Gateway Industrial Power Inc.	1.00 LS	980.00

Material Cost Subtotal	\$1,225.00
Markup on Material @ 10.00%	\$122.50
Profit on Material @10.00%	\$134.75
Material Subtotal	\$1,482.25

Labor	Rate	Quantity	Cost
Labor	79.84	16.00 Hr	1,277.44
Labor Subtotal			\$1,277.44

TOTAL 2,759.69

Note: This proposal may be withdrawn by us if not accepted within 30 days.

Submitted By:

Accepted By:

Signature: Leon J. Keller

Signature: _____

Name, Title: Leon J. Keller, President

Name, Title: _____

Date: February 20, 2017

Date: _____

cc. Joe Gruender, Little Dixie Construction

CERTIFIED COPY OF ORDER

STATE OF MISSOURI }
County of Boone } ea.

March Session of the January Adjourned

Term. 20 17

In the County Commission of said county, on the 16th day of March 20 17

the following, among other proceedings, were had, viz:

Now on this day the County Commission of the County of Boone does hereby authorize the approval of Change Order #52 to Boone County Emergency Communications Center Bid Number 44-11DEC14 to add a cabinet with recirculating hood and wet chemical fire extinguishing unit to the Central kitchen.

The terms of the Change Order are stipulated in the attached Change Order #52. It is further ordered that Commissioner Janet M. Thompson is hereby authorized to sign said Change Order.

Done this 16th day of March, 2017.

ATTEST:

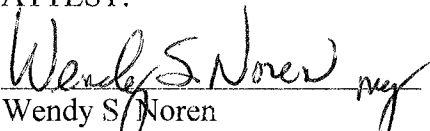

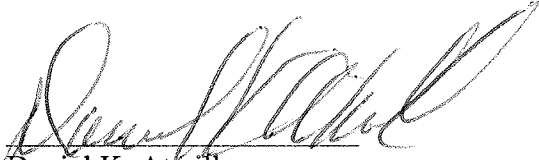
Wendy S. Noren
Clerk of the County Commission

Daniel K. Atwill

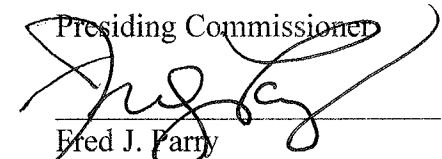
Presiding Commissioner

Fred J. Farry

District I Commissioner

Janet M. Thompson

District II Commissioner

CHANGE ORDER

PROJECT:
Boone County Emergency Communications Center
Bid Number 44-11DEC14

CHANGE ORDER NUMBER: 52

OWNER:
Boone County Commission
Boone County Government Center
801 E. Walnut, Rm 333
Columbia, MO 65201-7732

DATE OF ISSUANCE: 3/10/2016
CONTRACT DATE: 1/27/2015

ADG PROJECT NUMBER: 916-13
PWA PROJECT NUMBER: 201340

TO CONTRACTOR:
Little Dixie Construction, LLC
3316 Lemone Industrial Blvd.
Columbia, Missouri 65201

ARCHITECT:
Architects Design Group
333 Knowles Ave.
Winter Park Florida 32789

PWArchitects, Inc.
15 S. Tenth Street
Columbia, MO 65201

Change Order Number 52:

The Contract is changed as follows:

1. Add a cabinet with recirculating hood and wet chemical fire extinguishing unit to the Central Kitchen as requested by the Owner per RFP #43 and Change Order Request #095.....
.....\$ 10,800.00
- Total CO #52\$ 10,800.00**

Not valid until signed by the Owner, Architect and Contractor.

The original Contract Sum was	\$ 9,933,707.00
Net change by previously authorized Change Orders	\$ 871,577.89
The Contract Sum prior to this Change Order was	\$ 10,805,284.89
The Contract Sum will be increased/ decreased by this Change Order in the amount of	\$ 10,800.00
The new Contract Sum including this Change Order will be	\$ 10,816,084.89
The Original Contract Time +/- previous change orders for the project was	297 days
Contract Period for Construction is Increased/Decreased by	0 days
New Contract Period for New Building and Site	297 days
Contract Completion Date is	April 29, 2016

ARCHITECT
Architect's Agent
Erik Miller, AIA, CDT
Principal, PWA Architects, Inc.

BY 

DATE 3-13-17

CONTRACTOR
Little Dixie Construction, LLC
John States
Owner

BY 

DATE 3-13-17

OWNER
Boone County, Missouri
Janet M. Thompson
District II Commissioner

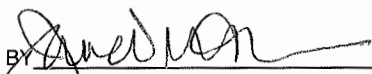
BY 

DATE 3/16/17

CERTIFICATION:

I certify that this contract is within the purpose of the appropriation to which it is to be charged and there is an unencumbered balance of such appropriation sufficient to pay the costs arising from this contract.

Jane Pitchford by HA 3-13-17
Auditor Date

OWNER'S REPRESENTATIVE
Boone County Resource Management
Doug Coley
Director of Facilities

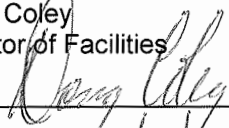
BY 

DATE 3/13/17



3316 LeMone Industrial Blvd. / Columbia, Missouri 65201 / office 573.449.7200 / fax 573.449.7300
littledixieconstruction.com

CHANGE ORDER REQUEST #095

PROJECT: Boone County Emergency
Communication Center
2145 E County Drive
Columbia, MO 65202

LDC# 15010

Request Submitted to: Janet Thompson
Boone County Commission
801 E. Walnut, Room 333
Columbia, MO 65201-7732

Phone: 573-886-4305

Description	Base Cost	Electrical
PW Architects Request For Proposal Number 43		
LDC Mobilization	\$ 1,500	
Seville Woodworks	\$ 805	
Teel Mechanical	\$ 4,955	
Meyer Electric		\$ 1,633
LDC Clean Up	\$ 1,200	
	\$ 8,460	\$ 1,633
<i>7% General Conditions, Profit & Overhead</i>	\$ 592	\$ 114
<i>Subtotals</i>	\$ 9,053	\$ 1,747
TOTAL	\$10,800	

Attachments:
 PW Architects Request For Proposal #43 dated 2/7/2017
 Seville Woodworks Change Order Request Proposal #10546 dated 2/8/2017
 Teel Mechanical Change Order Request Proposal #099 dated February 8th, 2017
 Meyer Electric Change Order Request #23882 dated 2/9/2017

Time Extension Request: 0 Work Days

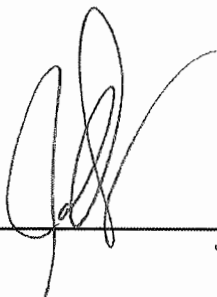
SUBMITTED BY: 
 John L. States, Member

DATE: _____

PROPOSAL REQUEST

PROJECT:

Boone County Emergency Communications Center
Bid Number 44-11DEC14

REQUEST FOR PROPOSAL NUMBER: 43

DATE OF ISSUANCE: 2/7/2017
CONTRACT DATE: 1/27/2015

OWNER:

Boone County Commission
Boone County Government Center
801 E. Walnut, Rm 333
Columbia, MO 65201-7732

ADG PROJECT NUMBER: 916-13
PWA PROJECT NUMBER: 201340

TO CONTRACTOR:

Little Dixie Construction, LLC
3316 Lemone Industrial Blvd.
Columbia, Missouri 65201

ARCHITECT:

Architects Design Group
333 Knowles Ave.
Winter Park Florida 32789

PWArchitects, Inc.
15 S. Tenth Street
Columbia, MO 65201

Please submit an itemized proposal for changes in the Contract Sum and Contract Time for proposed modifications to the Contract Documents described herein. Submit proposal within 10 business days, or notify the Architect in writing of the date on which you anticipate submitting your proposal.

THIS IS NOT A CHANGE ORDER, A CONSTRUCTION CHANGE DIRECTIVE OR A DIRECTION TO PROCEED WITH THE WORK DESCRIBED IN THE PROPOSED MODIFICATIONS. AN OFFICIAL CHANGE ORDER WILL FOLLOW ONLY AFTER THIS REQUEST HAS BEEN RESPONDED TO WITH AN OFFICIAL APPROVAL TO PROCEED BY THE OWNER.

Description:

1. Provide pricing to add a single wall cabinet with a recirculating range hood and wet chemical fire extinguishing unit. All new electrical circuits should be installed in panel P4. The electrical work should be priced separately within the proposal.

Attachment/s: North Elevation at Kitchen 177A, Guardian III cut sheet, Broan Cut Sheet.

By: Erik Miller, AIA, CDT
PWArchitects, Inc. (PWA)

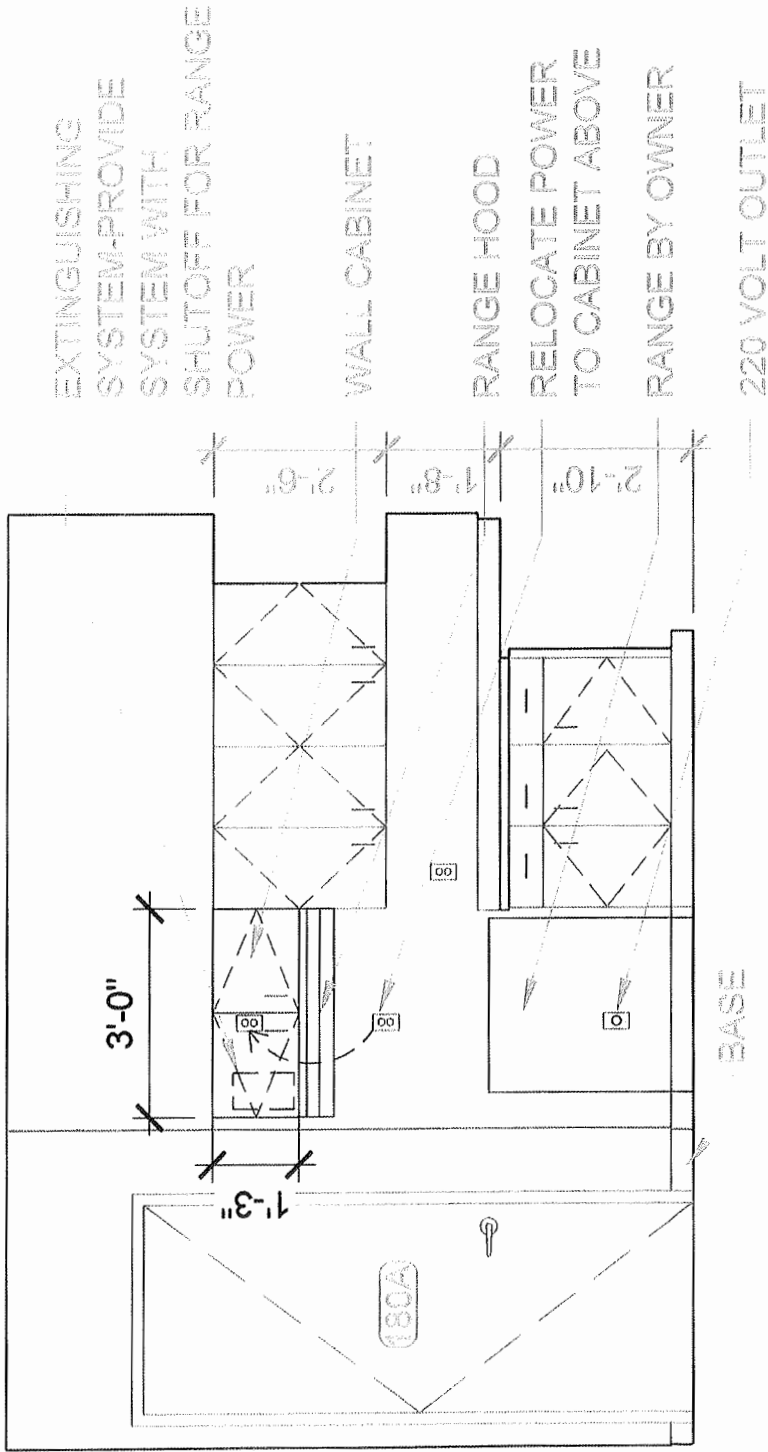

EXTINGUISHING SYSTEM-PROVIDE SYSTEM WITH SHUTOFF FOR RANGE POWER

WALL CABINET

RANGE HOOD
RELOCATE POWER TO CABINET ABOVE RANGE BY OWNER

220 VOLT OUTLET

NORTH

INTERIOR ELEVATION - CENTRAL KITCHEN

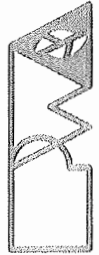

PWA Architects, Inc.

Missouri Registered Professional Architect No. 0002444

ID 2.05A
Sheet 1 of 1

BOONE COUNTY EMERGENCY COMMUNICATIONS CENTER-RFP #37

EM

02/07/2017



THE GUARDIAN III
™ *Stops Rangetop Fires Instantly*

OWNER'S MANUAL

For Installation, Operation and Maintenance

MODEL G300-A

Wet Chemical Extinguisher Unit

UL FILE NO. EX 3940

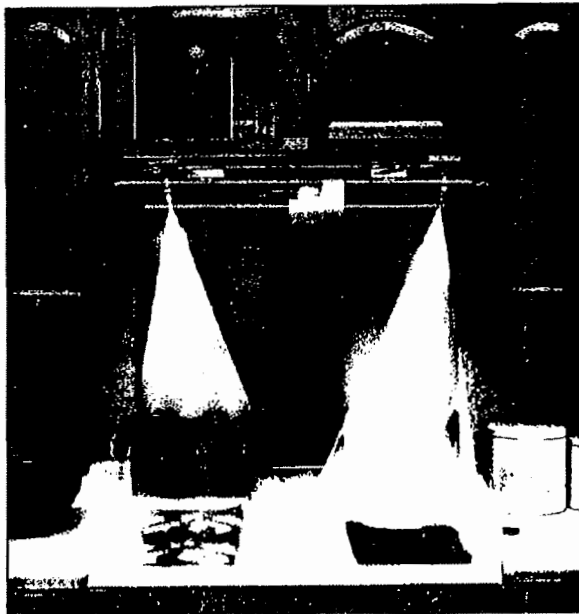

PATENTED



TWENTY FIRST CENTURY

International Fire Equipment And Services Corporation
3249 West Story Road· Irving, TX 75038

Revised
February 20, 2007

G310A-A

F40000 SERIES TWO-SPEED 4-WAY CONVERTIBLE RANGE HOOD

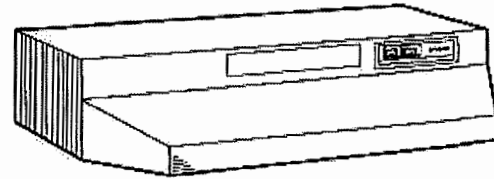

Constructed with quality and good looks, the F40000 is superior to the competition whether ducted vertically, horizontally, or non-ducted.

FEATURES

- Two speed fan control
- Polymeric blade and light lens (accepts up to 75W bulb)
- Washable aluminum filter
- Converts to non-ducted by removing cover plate from front of hood and installing the non-ducted filter (purchase separately)
- Mitered sides and hemmed bottom for safety and good looks
- Damper/duct connector included
- 7" round plate included
- Contemporary styling in White, Almond, Biscuit, and Stainless Steel
- Available in 24, 30, 36 and 42" widths

SPECIFICATIONS

VOLTS	AMPS	RPM	CFM	SONES	DUCT
120	2.5	2850	160	6.5	3 1/4" x 10" (H)
120	2.0	2850	160	6.5	3 1/4" x 10" (V)
120	2.0	2850	190	6.5	7" Round (V)
120	2.0	2850	--	--	Non-ducted



HVI-2100 CERTIFIED RATINGS comply with new testing technologies and procedures prescribed by the Home Ventilating Institute, for off-the-shelf products, as they are available to consumers. Product performance is rated at 0.1 in. static pressure, based on tests conducted in AMCA's state-of-the-art test laboratory. Sones are a measure of humanly-perceived loudness, based on laboratory measurements.



TYPICAL SPECIFICATION

Range hood shall be Broan Model F40000.

Unit shall be convertible between ducted using a washable aluminum filter (included) and non-ducted (purchase non-ducted filter separately).

Motor to be permanently lubricated. RPM not to exceed 2850.

Unit shall have a two-speed fan switch with separate light switch.

Sides shall be mitered and bottom edge hemmed - with no sharp edges.

Air delivery shall be no less than 160 CFM and sound levels no greater than 6.5 Sones (3 1/4" x 10" horizontal and vertical discharge) or 190 CFM at 6.5 Sones (7" round discharge). All air and sound ratings shall be certified by HVI.

Unit shall be U.L. listed.

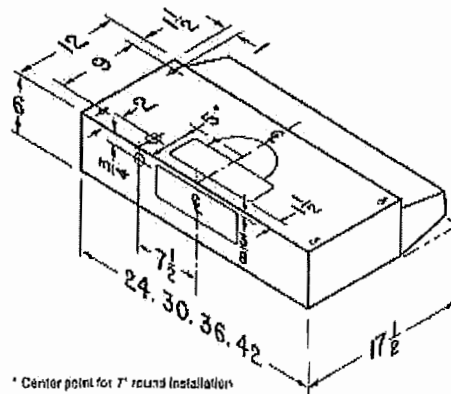

Broan-NuTone LLC, 926 West State Street, Hartford, WI 53027 (1-800-637-1453)

REFERENCE	QTY.	REMARKS	Project
			Location
			Architect
			Engineer
			Contractor
			Submitted by
			Date



Proposal

Date	Proposal #
2/8/2017	10546

Bill To

Little Dixie Construction
 3316 LeMone Industrial Blvd.
 Columbia, MO 65201

Project / Job / P.O. Number
BCECC

Item	Description	Qty	Rate	Amount
Casework	BCECC Request for Proposal #43 Includes: Installation of cabinet only Does not include: Range hood, wet chemical fire extinguishing unit, electrical, electrical cutouts 177A Kitchen ADD 1 wall cabinet, stained to match existing, 36" x 15"		675.00	675.00
Installation	Sales Tax		130.00 7.975%	130.00 0.00

Total	\$805.00
--------------	-----------------

- * This Proposal is valid for 45 days.
- * Seville Woodworks is not AWI certified. All work meets or exceeds AWI Custom. Items Custom Made to Specifications.
- * Payments will be due upon receipt of invoice. If payment is not received within 30 days, material acquisition and production of custom casework will stop, and a 2% late fee will be added to invoice.
- * Client is responsible for providing current blueprints, specifications, and notes.
- * Shop Drawings must be approved by Client before manufacturing of casework can begin. Our shop drawings and proposal are a direct interpretation of the blueprints and specifications. We intend, as your partner, to provide shop drawings on a timely basis for your review. It is impossible to guarantee timely delivery without a proper review and a submittal of all requested information directly related to casework.
- * If job total is over \$5,000.00, deposit of 50% is required within 30 days of approved shop drawings.
- * Material Draw of 50% is required for any specialty product i.e. Quartz, Granite, 3Form, Lumicor, etc.
- * Progress, Shop Drawings Fee, Net 30, WIP or Stored Materials are billable.
- * Any alternations or modifications to this Proposal - The price therefore must be agreed upon by the parties in a written "Change Order," before work on such alteration or modification shall commence. Payment for such alteration or modification shall be made in accordance with the terms of the "Change Order".
- * Proposal includes cost of Shop Drawings. (Shop Drawings are property of Seville Woodworks.)
- * If Proposal includes Laminate and color/style choices have not been specified, this Proposal price is only for 1 color choice for Casework and 1 color choice for Countertops.
- * All sales are final.

- Exclusions --
- Any items listed on material, finish or hardware schedules that are not located or do not have their locations identified in specifications, plans, elevations or sections.
 - Concealed backing and blocking; Rubber Base; Metal in wall top supports and structures; Plumbing Hardware; Trash and waste containers
 - Off hour installation; Use of CG 2010 1185 additional insured form.
 - Signage, lighting or wiring at Reception Desk (if any- job specific); Fabric and acoustical panels, white boards (job specific)
 - Any metal or hanging system at wood ceiling planks; Premium Laminates
 - Not responsible for delays of job due to delays or backorders from materials manufacturers, or delay of materials selections.
 - If job is Installation only, complete payment without retainage is expected.
 - On-site consultation and layout.

Seville Woodworks

1516 I-70 Complex Ct.
 Columbia, MO 65201

Phone 573.442.4425
 Fax 573.442.5388
 office@sevillewoodworks.com
 www.sevillewoodworks.com

TEEL MECHANICAL SERVICE, INC.

Air Conditioning, Heating, Refrigeration, Ventilation

4388 County Road 203 • Fulton, Missouri 65251 • Phone (573) 642-9648 • Fax (573) 642-1313

February 8, 2017

Little Dixie Construction
3316 Lemone Ind. Blvd.
Columbia, MO 65201

Re: Boone County 911 Center

Change Order Request (RFP #43)

Price for 1 – Broan, Model F403604 Stainless Steel ³⁶30" Range Hood
Includes: Guardian II Fire Suppression, Install and Field Commissioned

Hood	\$ 2950.00
Labor – 16 hrs @ \$73.72/hr	<u>\$ 1179.52</u>
Subtotal	\$ 4129.52
20% OH&P	<u>\$ 825.90</u>
Total	\$ 4955.42

TOTAL CHANGE ORDER: \$ 4955.42

MEYER ELECTRIC INC.3513 North Ten Mile Drive
Jefferson City, MO 65109ph: (573) 893-2335 fax: (573) 893-3686
office@meyerelectric.netLittle Dixie Construction
3316 LeMone Industrial Blvd.
Columbia, MO 65201**CHANGE ORDER REQUEST**

2/9/2017

Boone County - Emerg. Comm.
Boone Co Comm C
Our Job #: 3620

Attention: Joe Gruender

Meyer Ref #: 23882
23882

RFP #43 - We propose to furnish material and labor to install electrical work, for RFP #43, per the following breakdown:

Material	Quantity	Cost	
SS single gang blank plate	1.00	2.85	
14-50R recpt	1.00	9.80	
SS plate for above recpt	1.00	4.20	
deep cut in boxes	3.00	11.85	
Madison hanger sets	2.00	3.90	
2 pole 50a GE shunt trip breaker bolt in	1.00	51.86	
8/3 with ground MC cable	45.00 ft	89.10	
12/2 MC shunt trip control	45.00 ft	20.70	
core drill and seal electric room wall	1.00	25.00	
MC connector for 8/3 w/ground	2.00	2.50	
MC straps	6.00	3.00	
MC connector	2.00	0.70	
MC straps	6.00	2.10	
Material Cost Subtotal		\$227.56	
Markup on Material @ 10.00%		\$22.77	
Profit on Material @10.00%		\$25.03	
Material Subtotal		\$275.36	
Labor	Rate	Quantity	Cost
Labor	79.84	17.00 Hr	1,357.28
Labor Subtotal			\$1,357.28
TOTAL			1,632.64

Submitted By:

Accepted By:

Signature:

Leon J. Keller

Signature:

Name, Title

Leon J. Keller, President

Name, Title

Date:

February 09, 2017

Date: